

# An overview of current Internet, Network Interconnectivity and Quality of Service

C. Pham

Université de Pau et des Pays de l'Adour

<http://www.univ-pau.fr/~cpham>

Congduc.Pham@univ-pau.fr



# The big-bang of the Internet

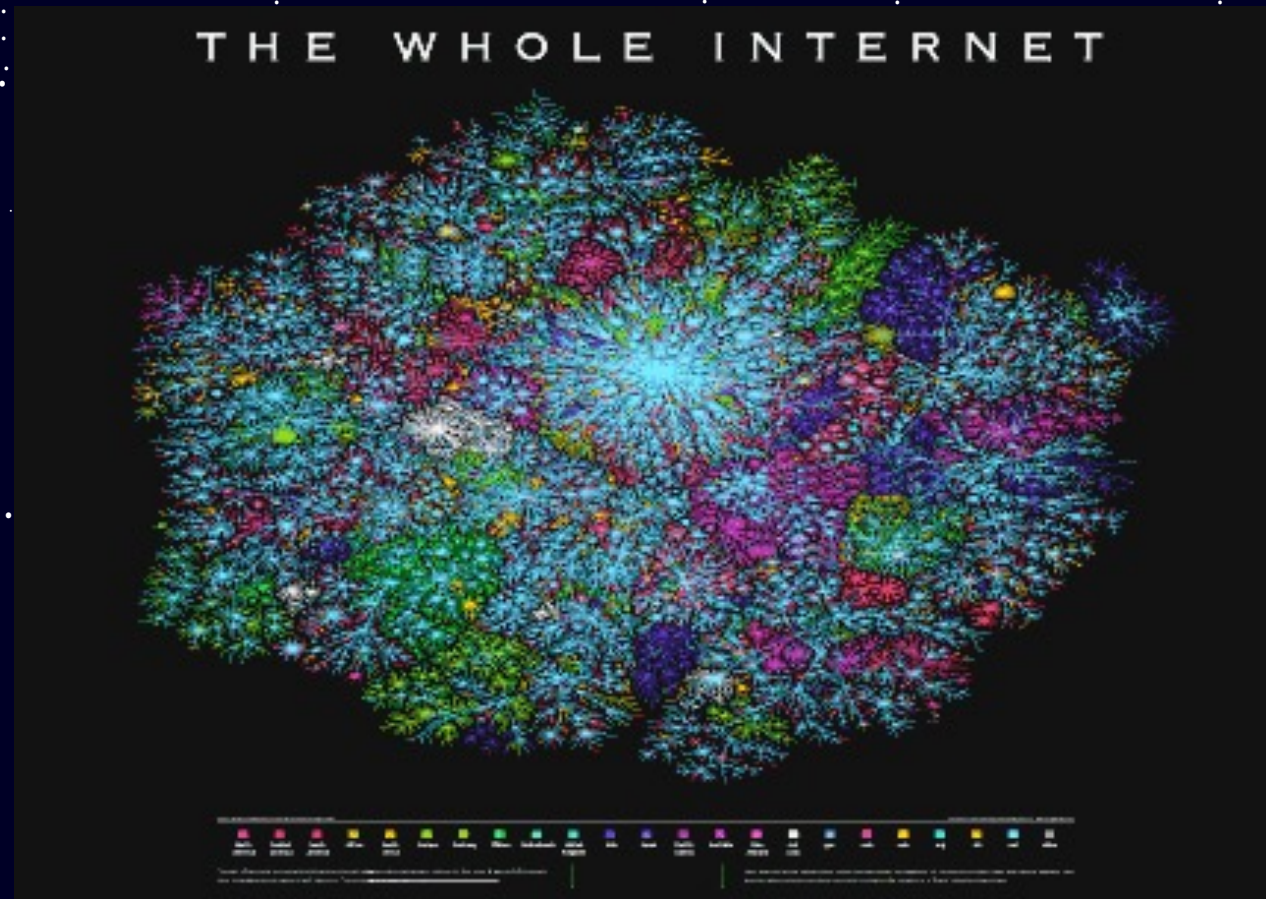
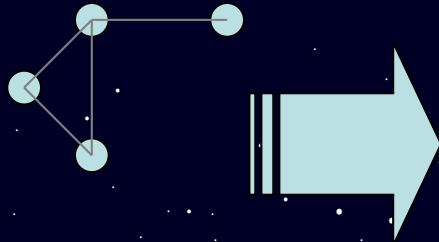

# # Internet host

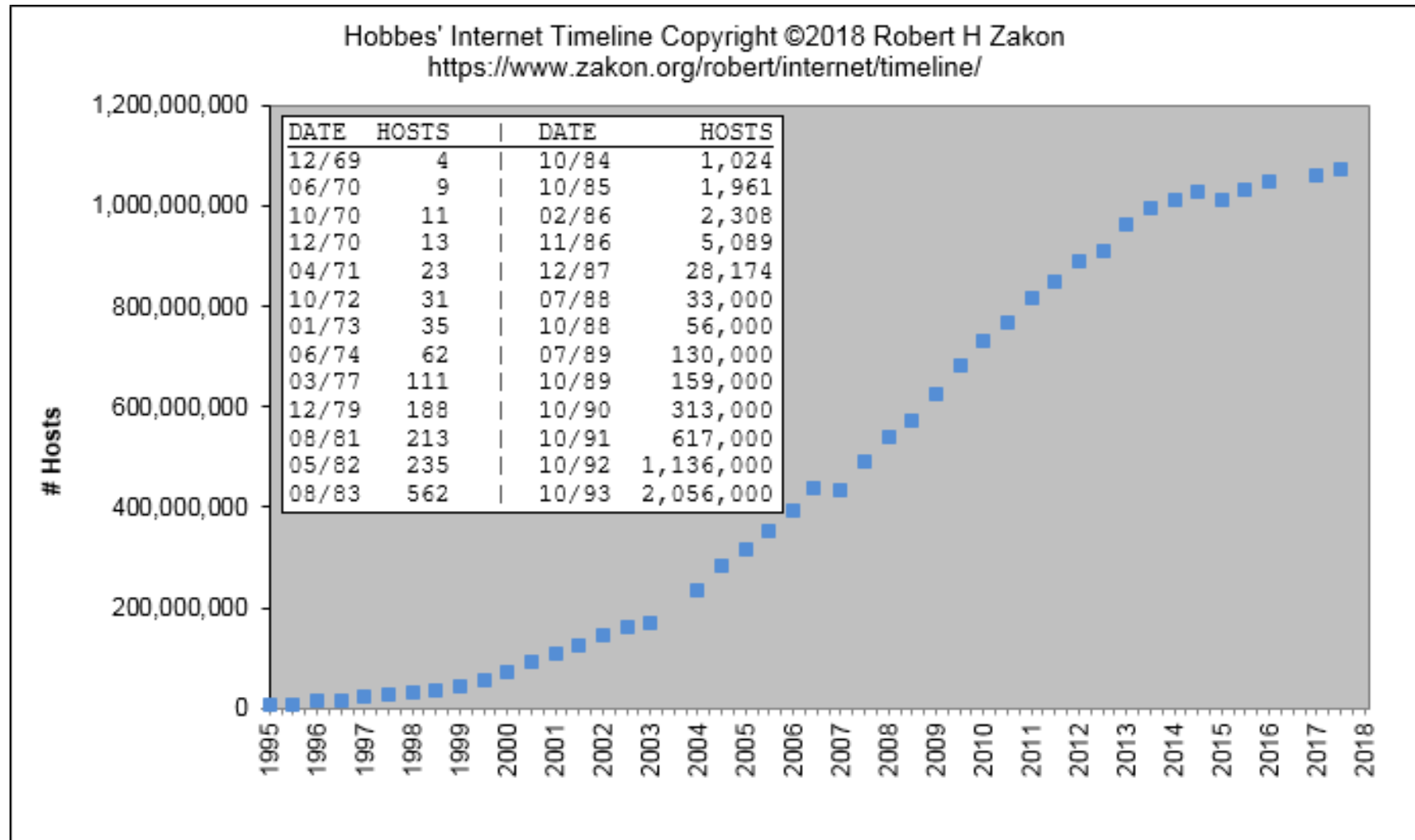

# # of www sites

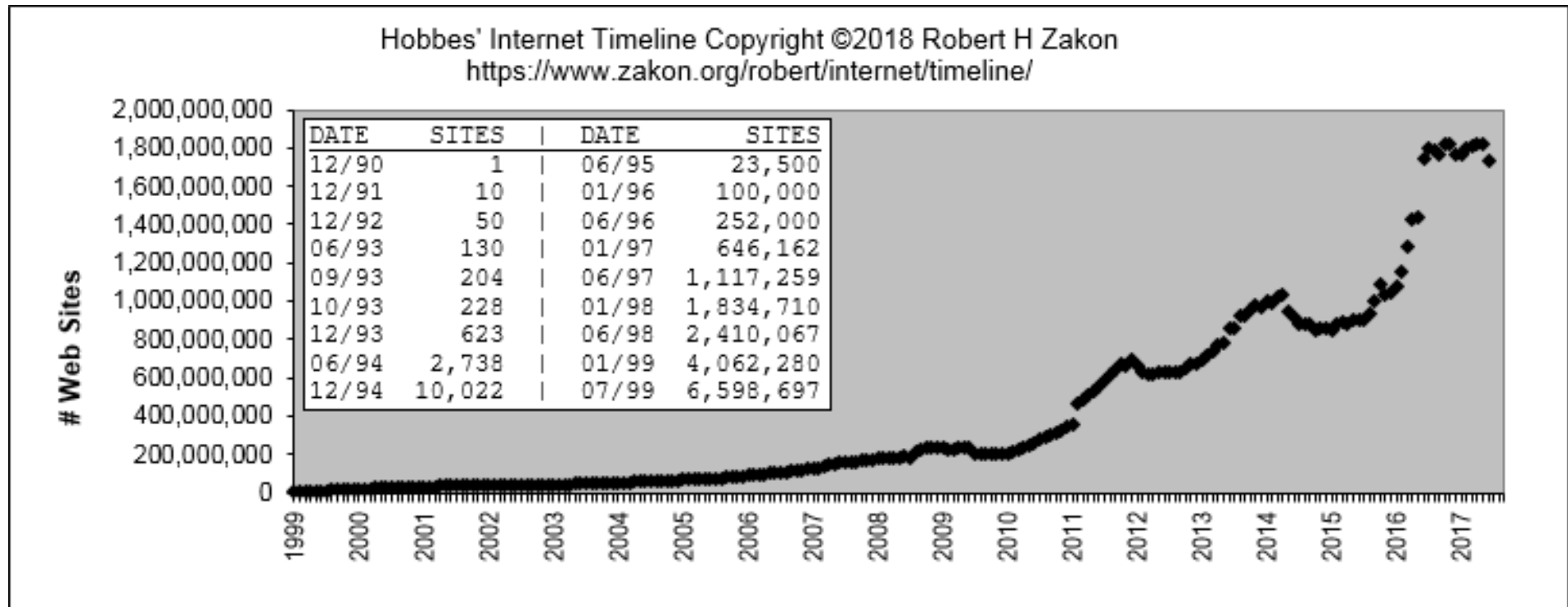

# # of facebook account

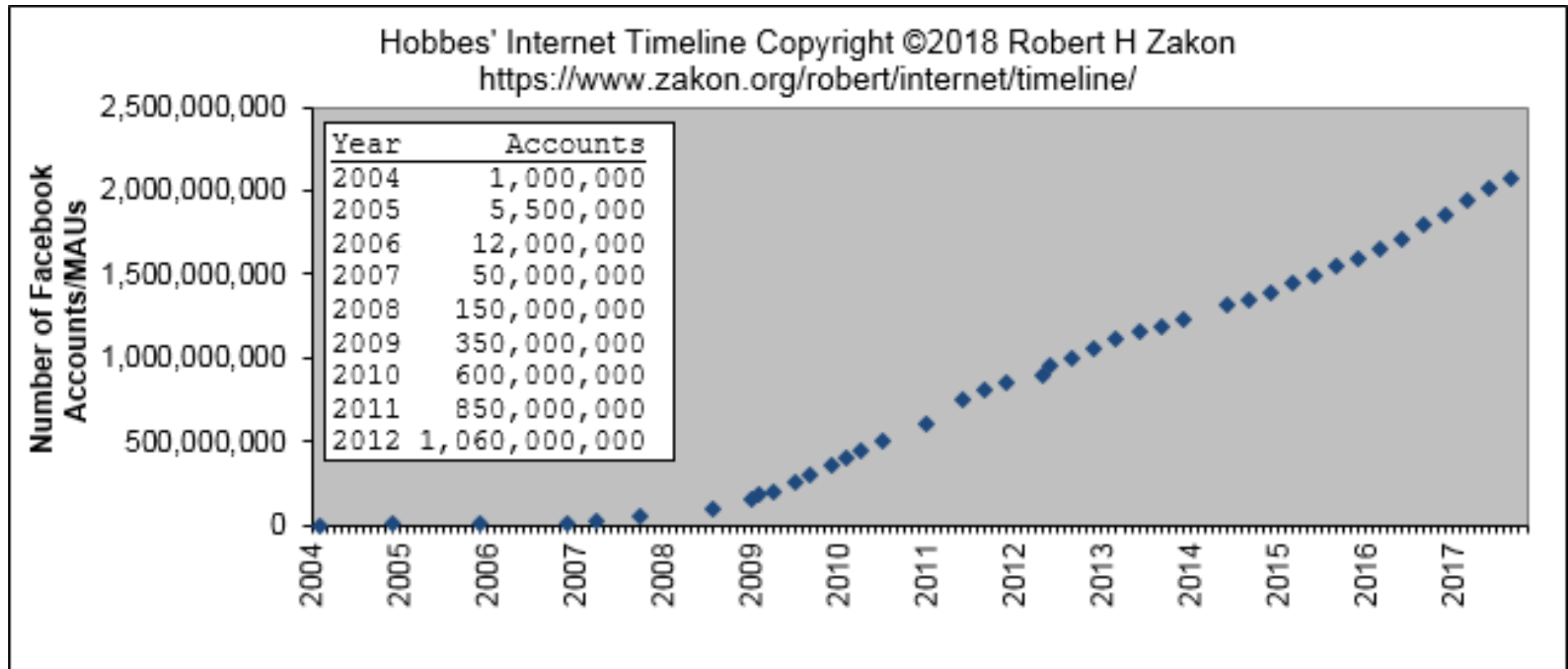

# Recent social media stats

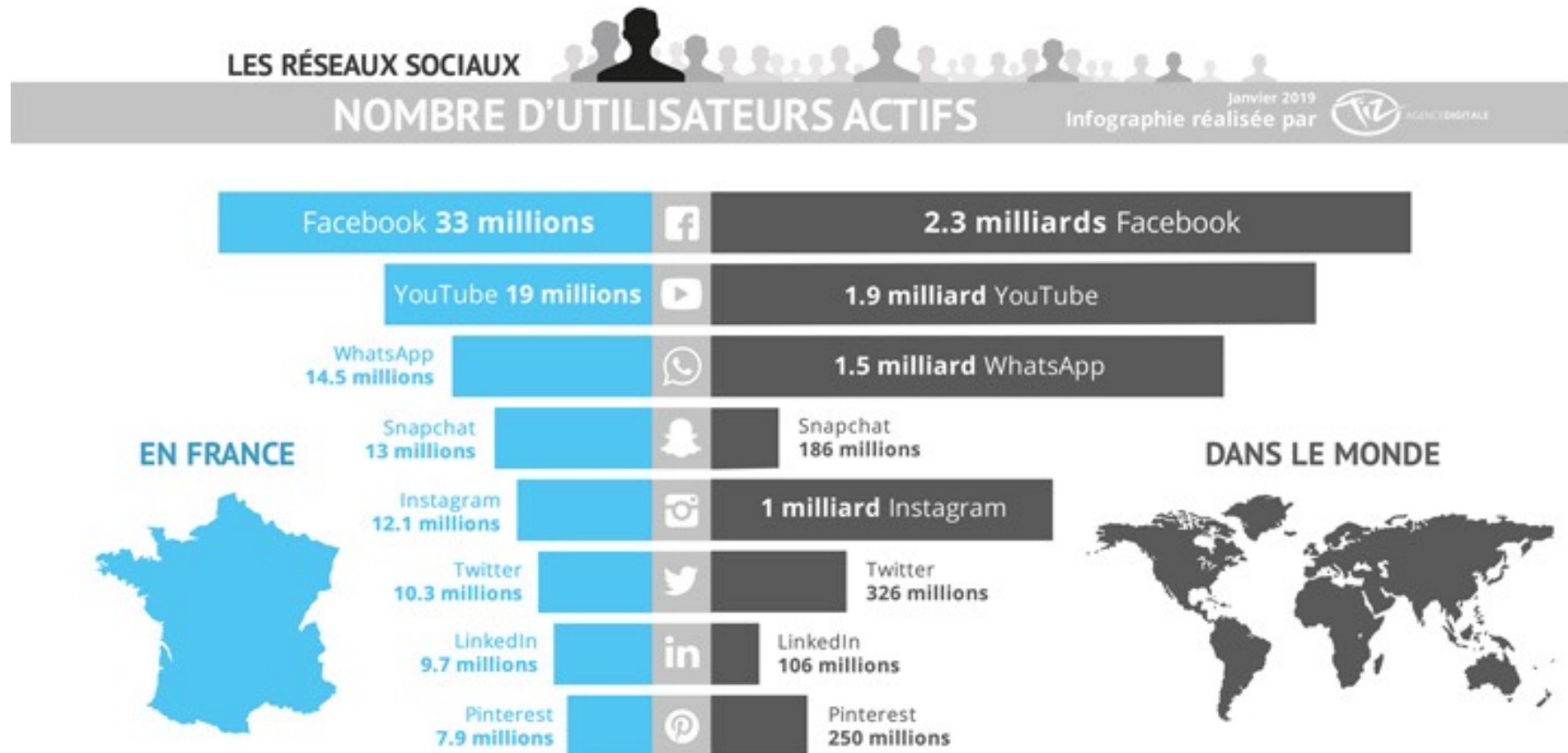

# Trafic evolution

## Augmentation du trafic Internet dans le monde

A la date du 27 mars 2020

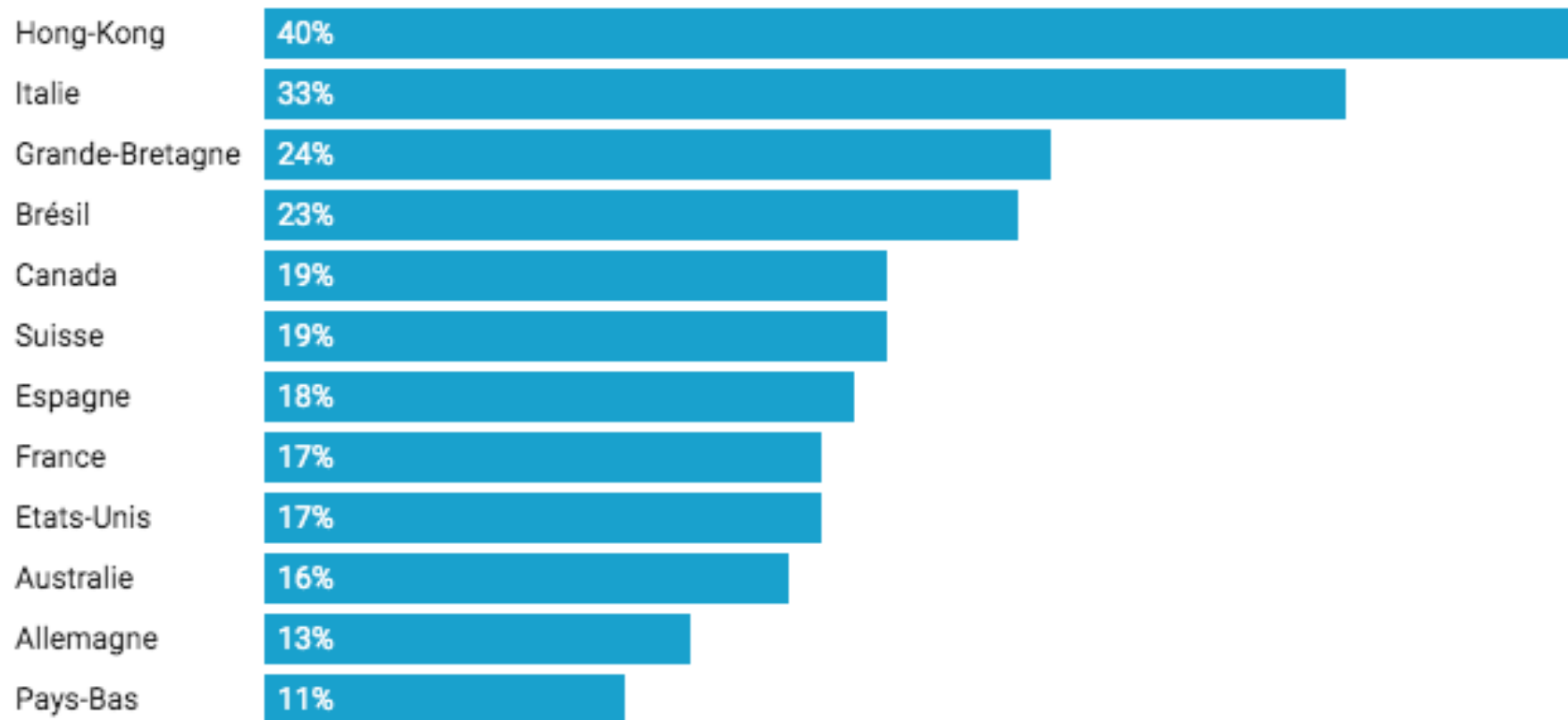

*Au niveau des principaux point d'échange du réseau (peering)*

Graphique: BFM Business • Source: Cisco • Créé avec Datawrapper

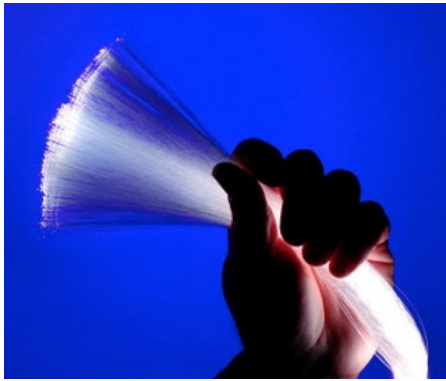

# 1<sup>st</sup> revolution: going optical

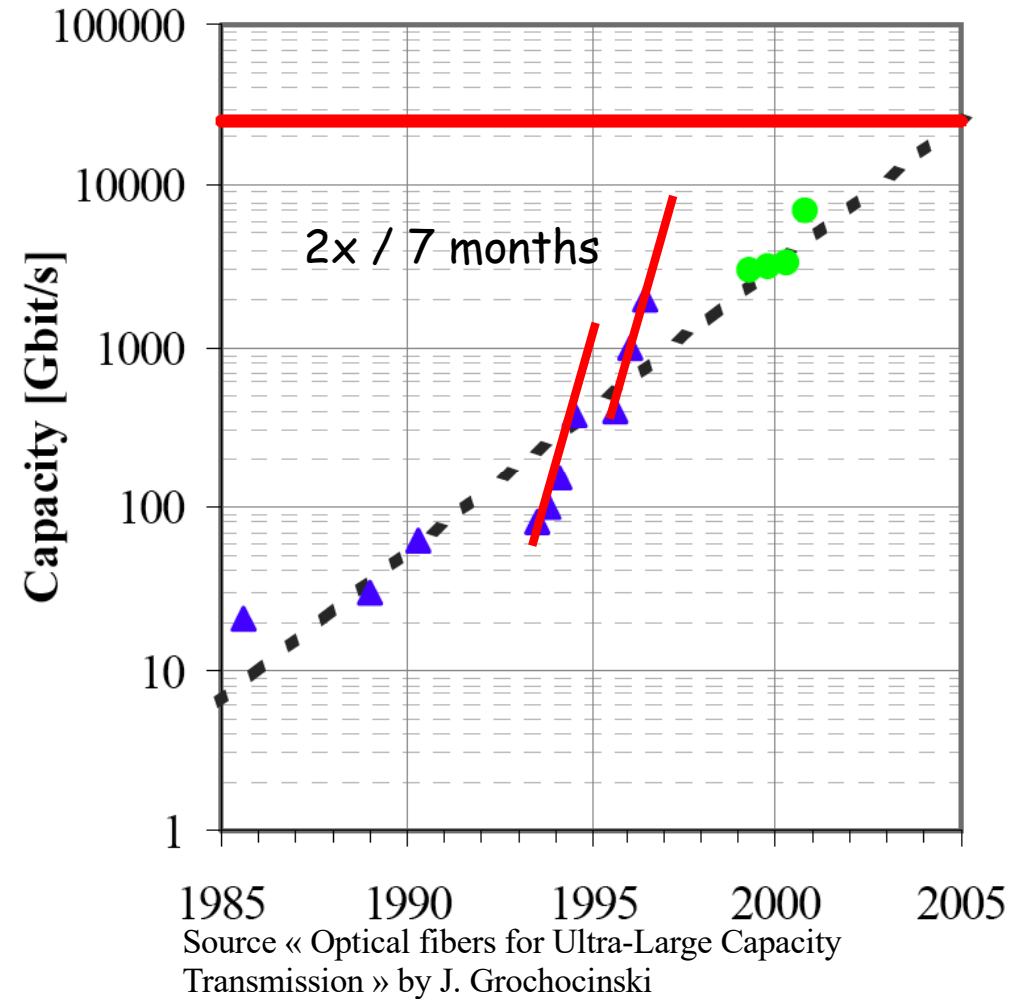
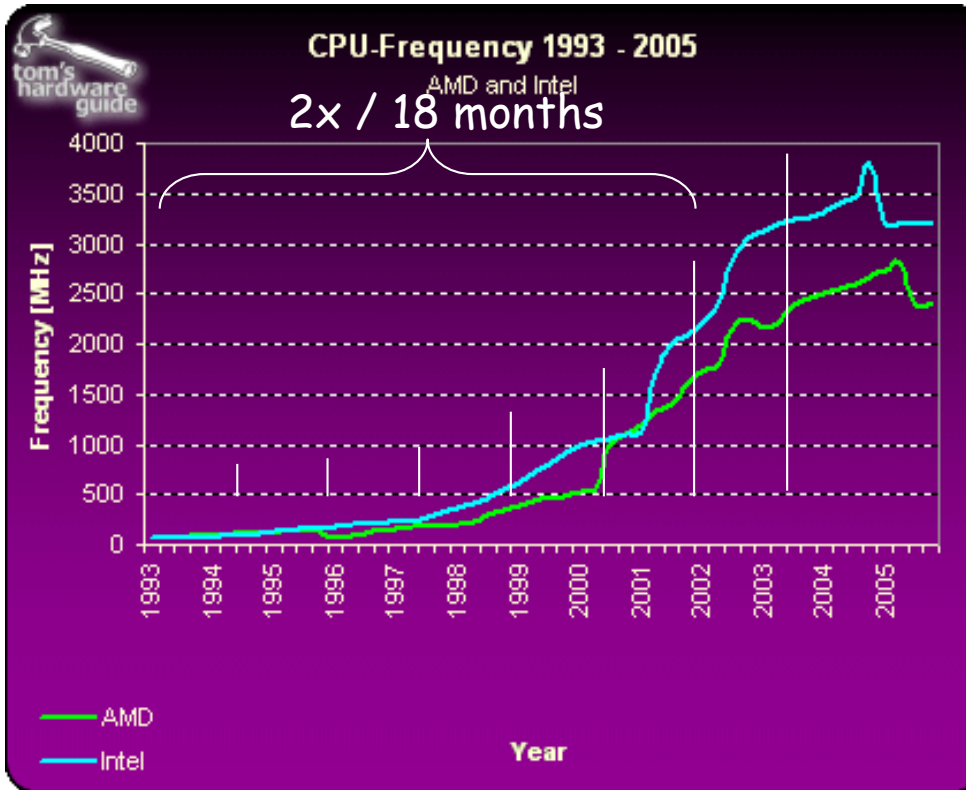



# DWDM, bandwidth for free?

DWDM: Dense Wavelength Division Multiplexing

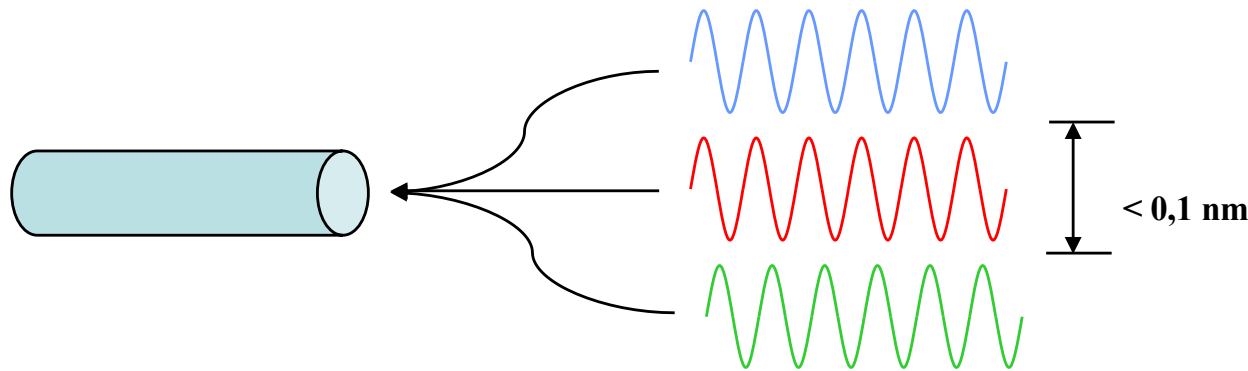

Submarine cable for deep sea areas



Submarine cable for shallow sea areas

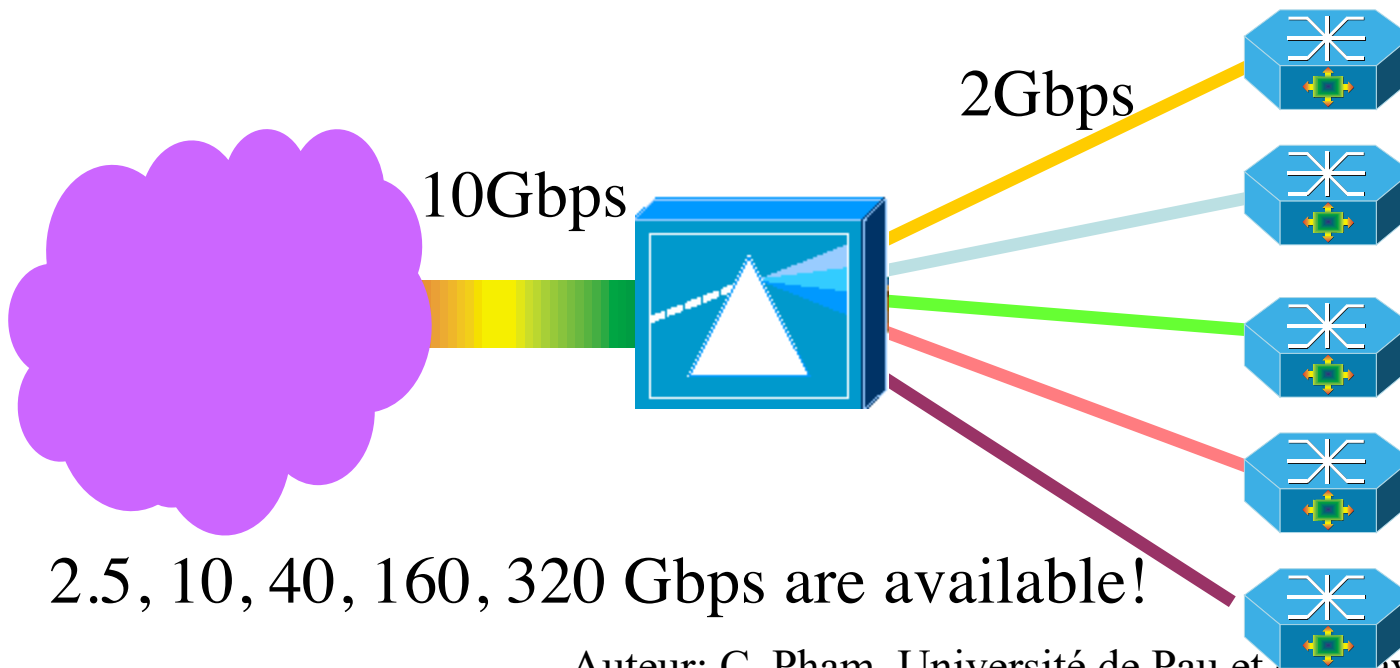

2.5, 10, 40, 160, 320 Gbps are available!



From Computer Desktop Encyclopedia  
Reproduced with permission.  
© 2001 Metromedia Fiber Network

# SDM, even more bandwidth!

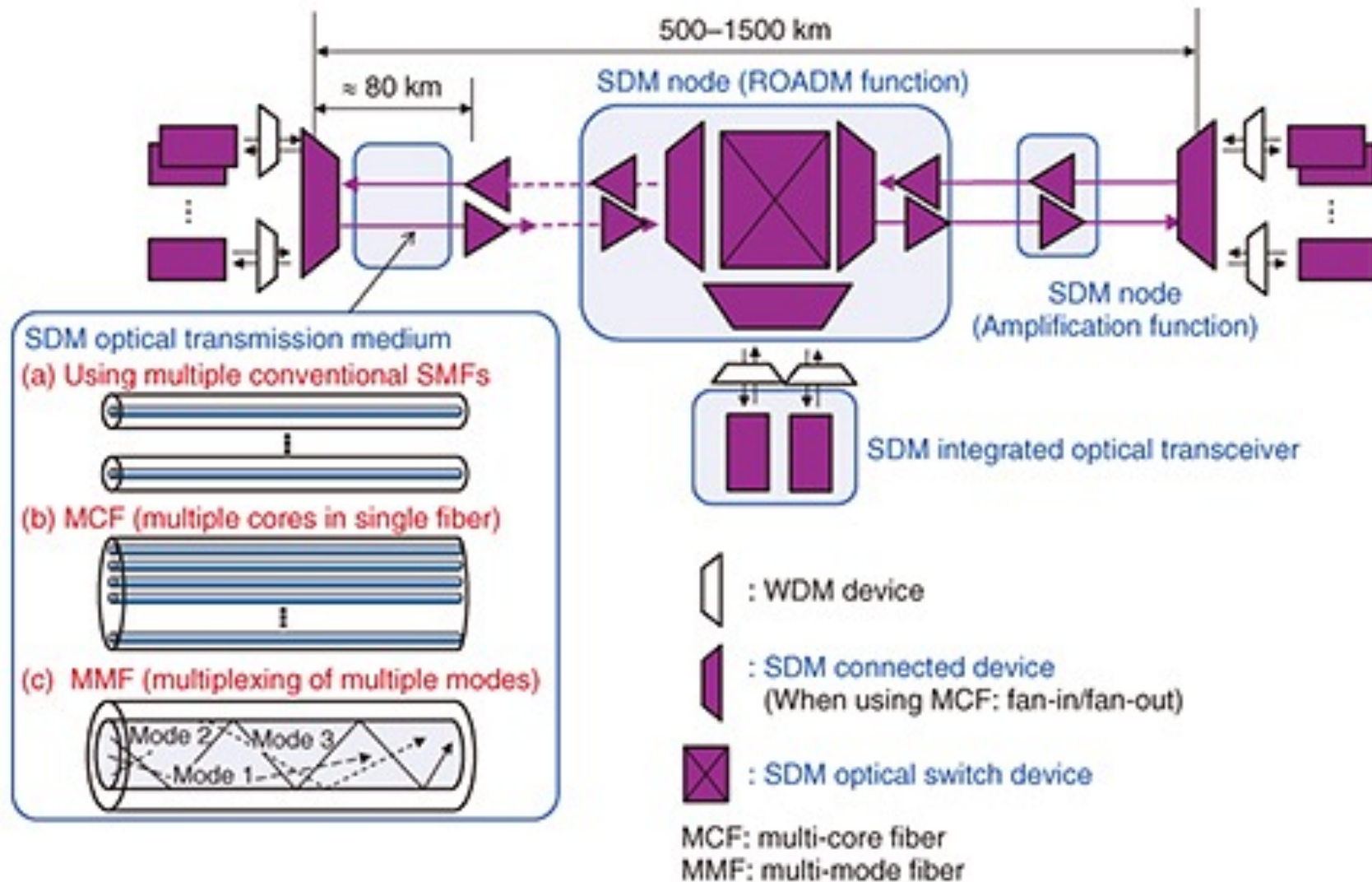

# Still big improvements in optical fibers!

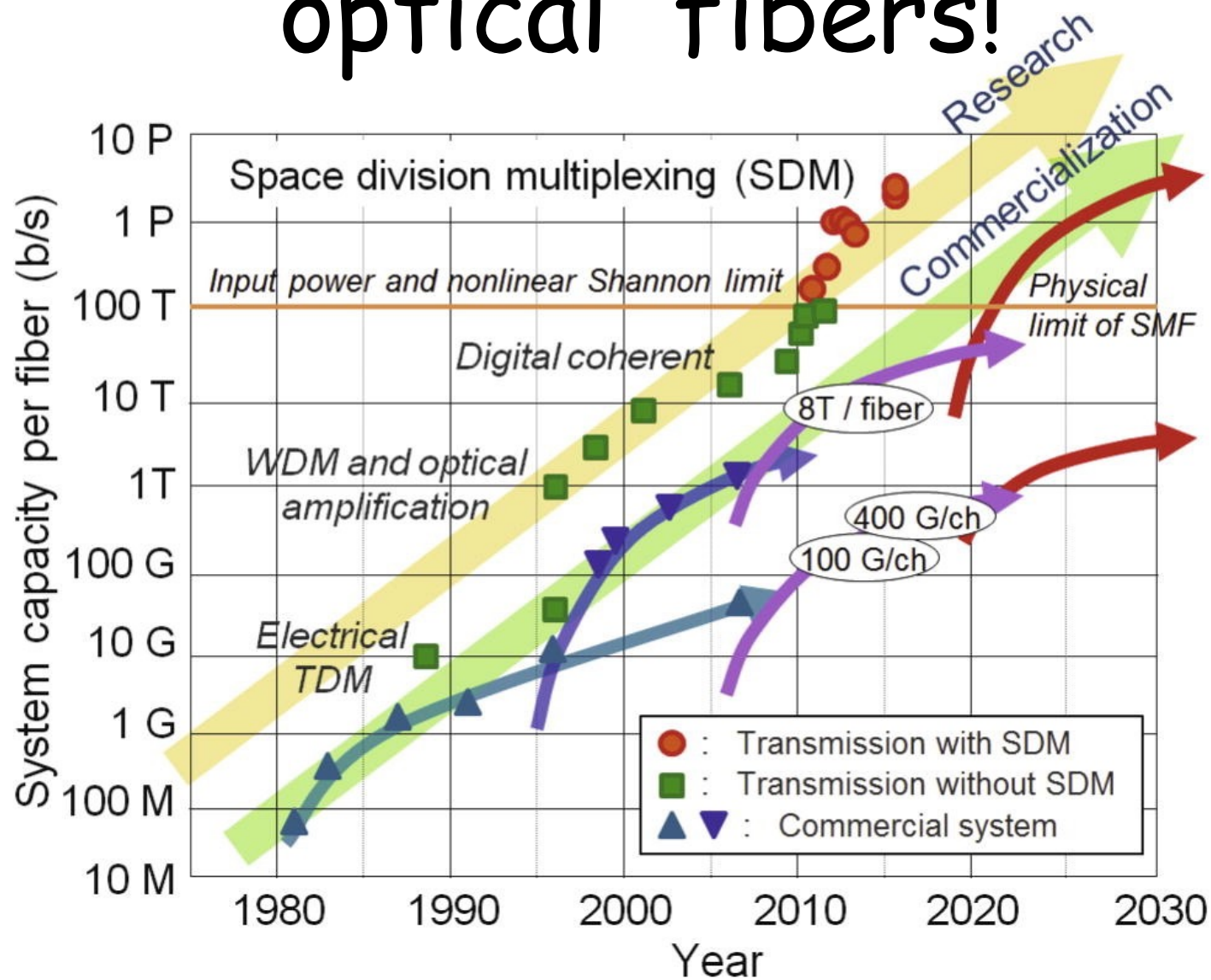

# Submarine optical fiber

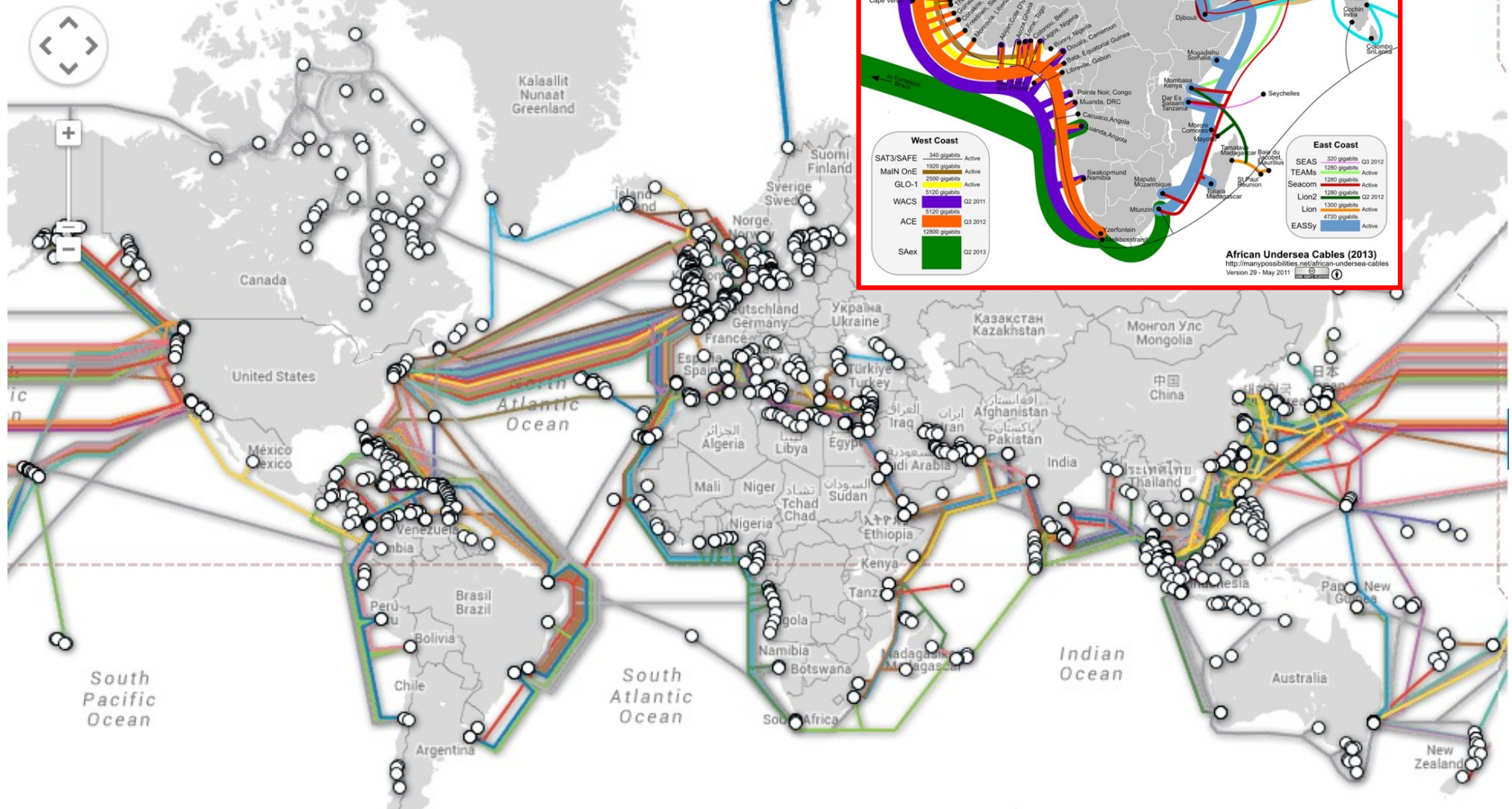

# Erbium Doped Fiber Amplifier

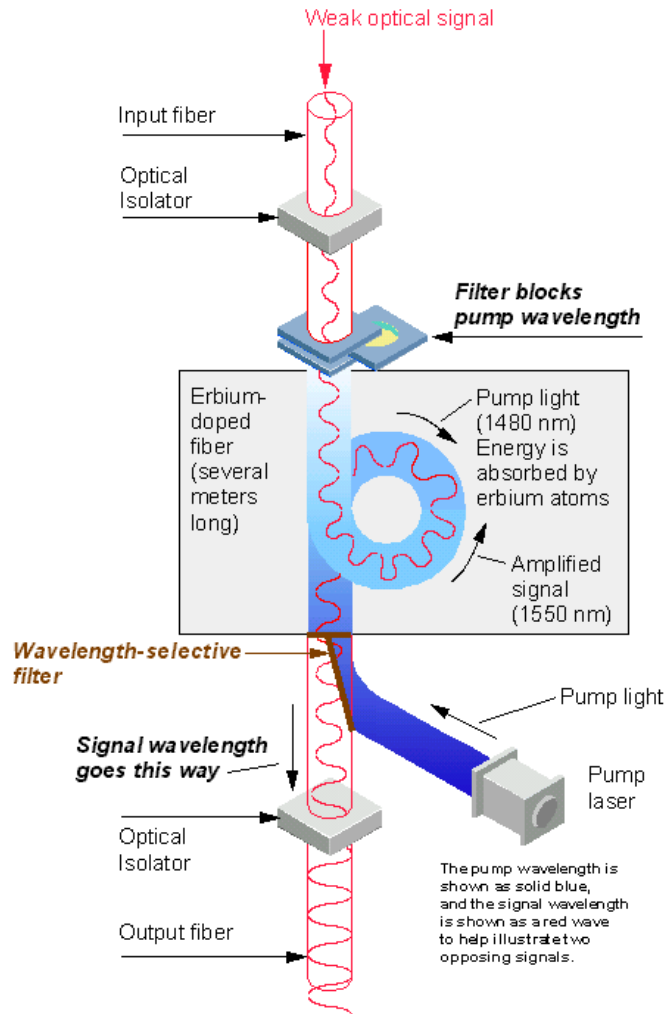

## What makes a Submarine Cable Network

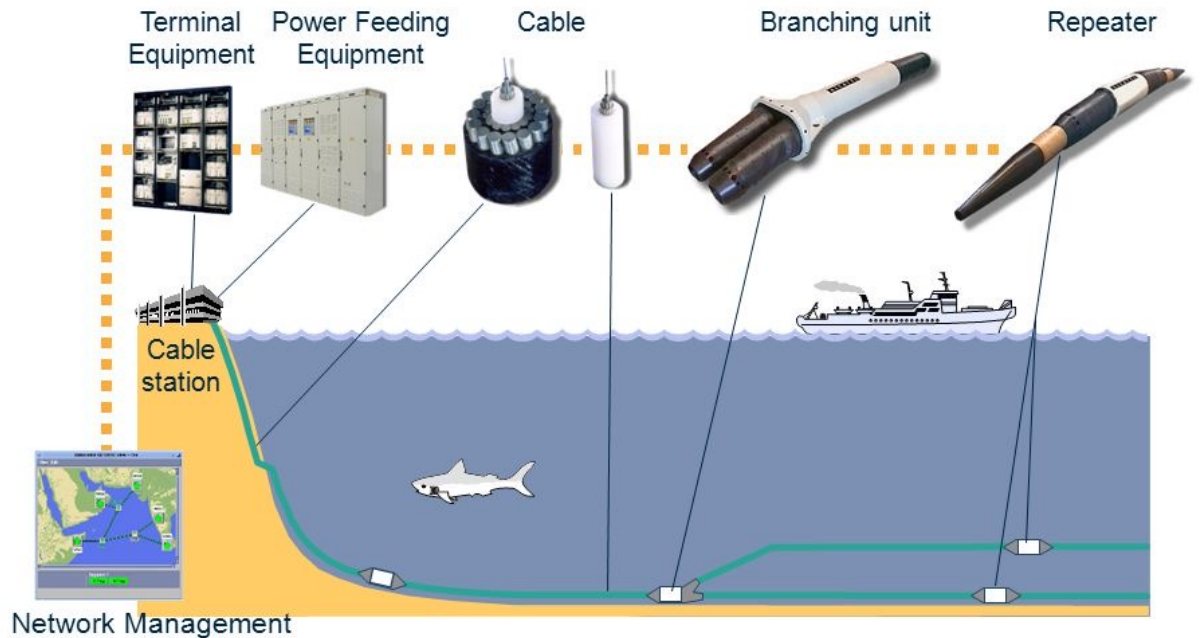

8

COMMERCIAL-IN-CONFIDENCE

SEACOM

# Internet core is 100% optical

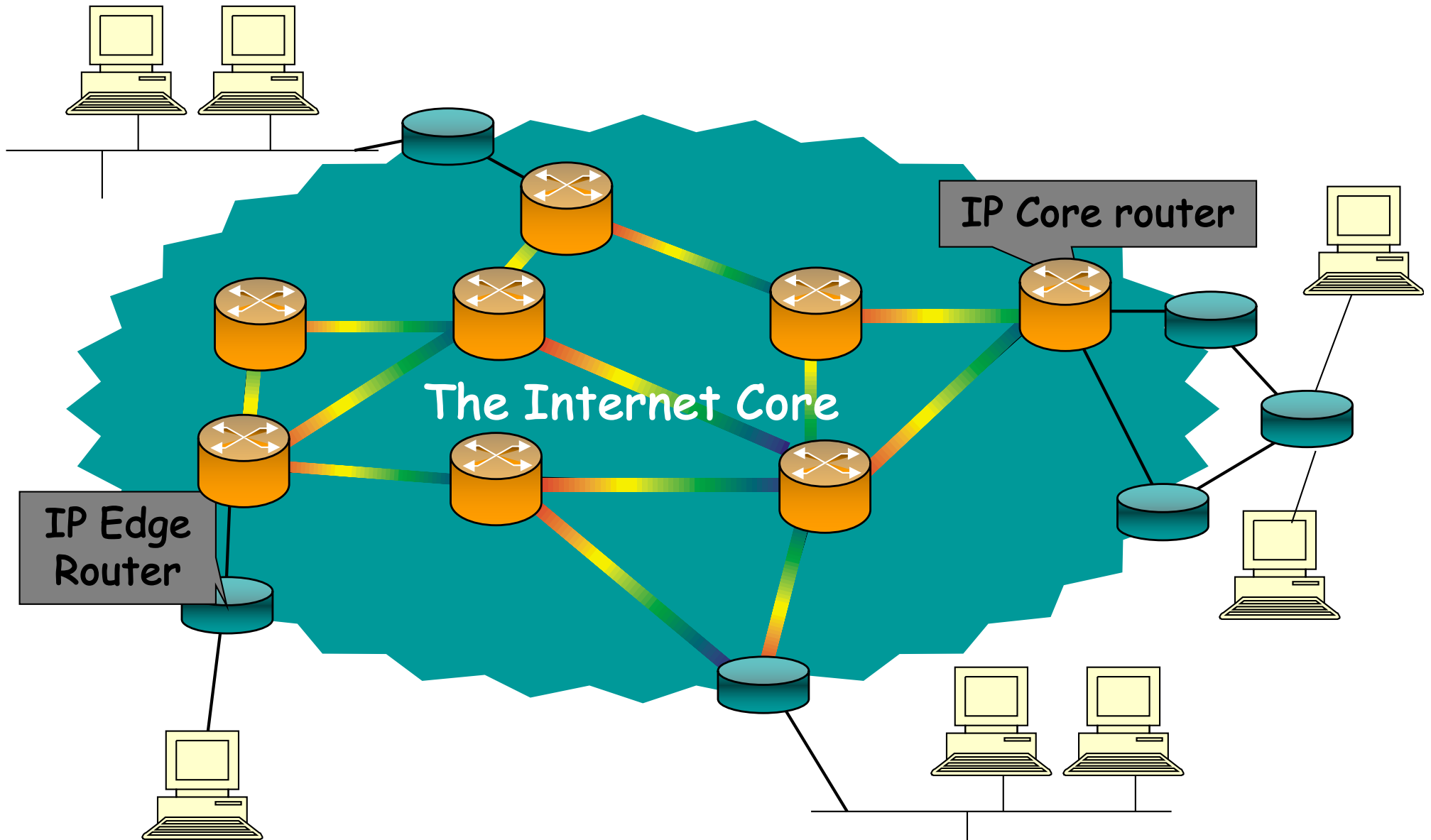

# Stimulating very high speed networks

user application

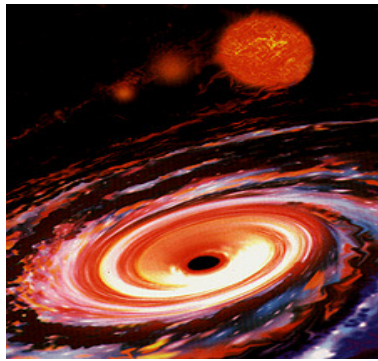

1PFlops

Virtually unlimited resources

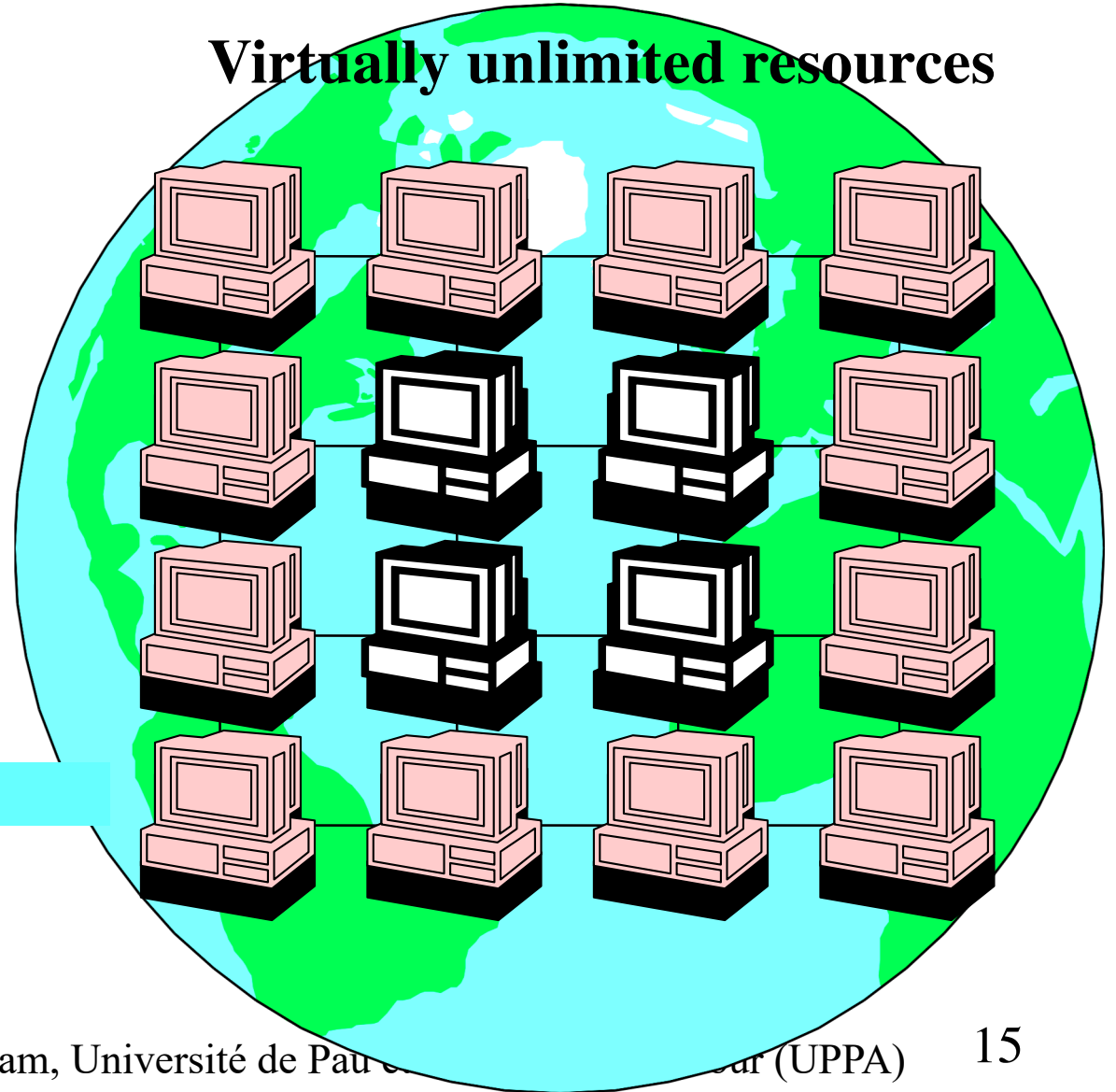

# GEANT network

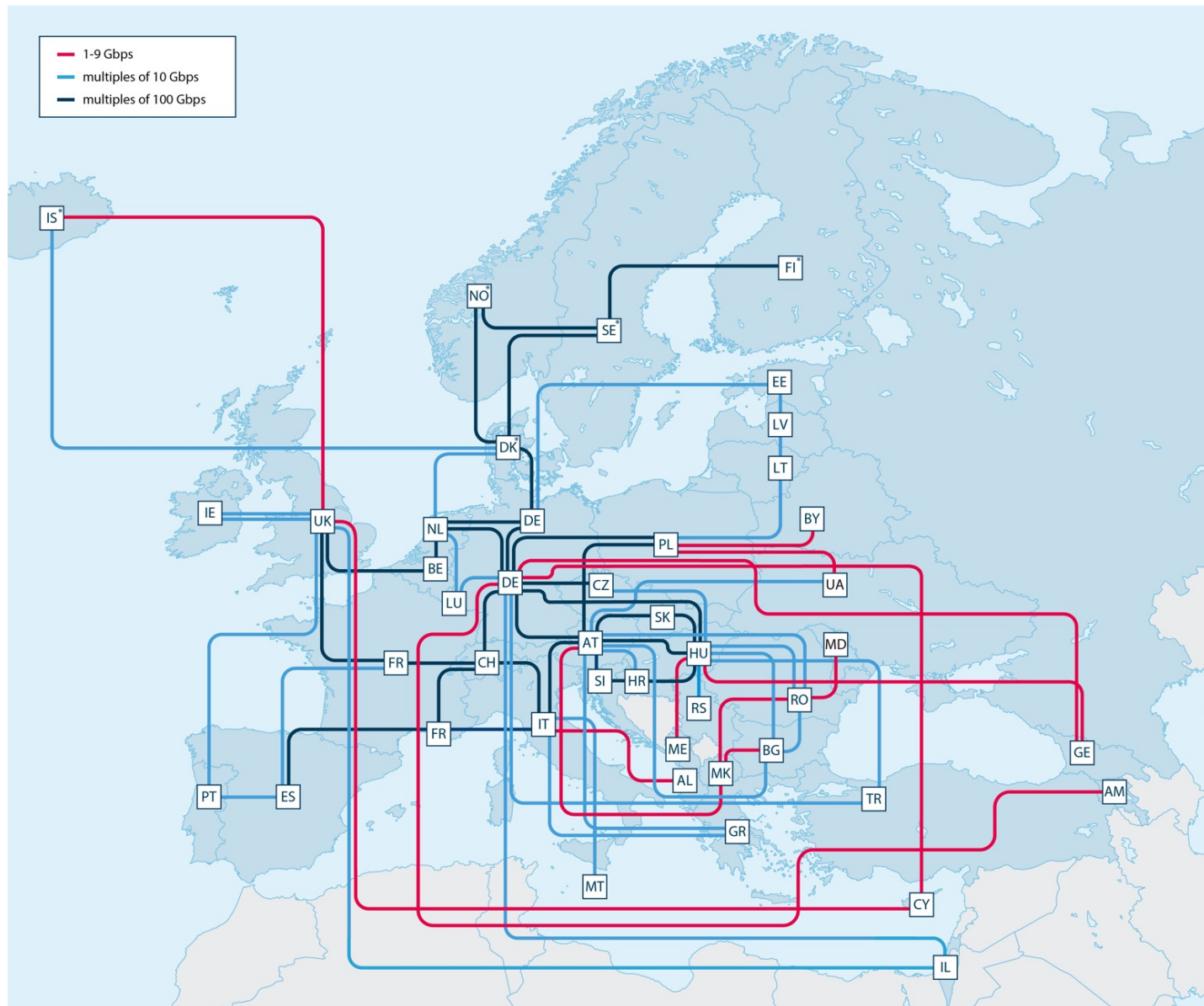



# GEANT networks & others

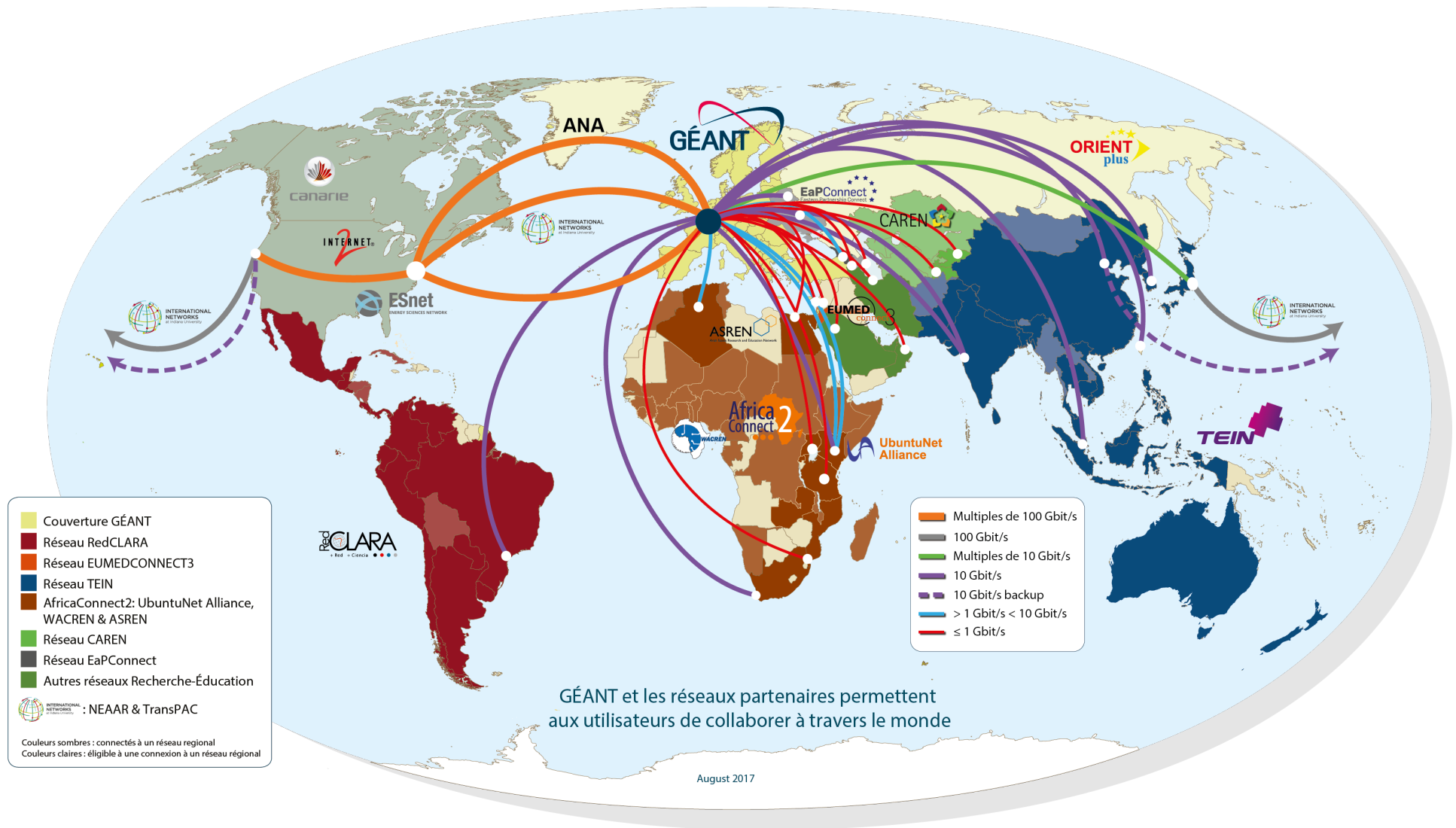

# Fibers everywhere?

NEWS of Dec 15th, 2004

Verizon and SBC are  
deploying large optical fiber  
in

NEWS for 2009

Japan remains the overall  
leader in terms of the number  
of fiber-connected homes at  
13.2 million, followed by the  
United States (6.05 million)  
and the People's Republic of  
China (5.96 million)

Total=24 millions!

NEWS from Japan and  
South Korea

NEWS of May 31st, 2005

US Fiber-to-the-home  
(FTTH) installations have

the first  
echnology  
at the  
gh-  
n  
ers

NEWS of July, 2011

France Telecom-Orange and  
Free will deploy FTTH in 5  
millions home distributed in  
1300 cities

ore  
160 Gbps

# Making it easier?

- Fibers that can be laid on the ground or burried under 20cm trench



**Dr. Haruo Okamura**  
**President**  
**Global Plan, Inc.**



<https://news.itu.int/new-itu-standard-can-help-bring-broadband-rural-communities/>

Auteur: C. Pham, Université de Pau et des Pays de l'Adour (UPPA)

# 2<sup>nd</sup> revolution: Wireless Networks

- ❑ WiFi, WiMax
- ❑ BlueTooth, ZigBee, IrDA...
- ❑ GSM, GPRS, EDGE, 3G, 4G, 5G, ...

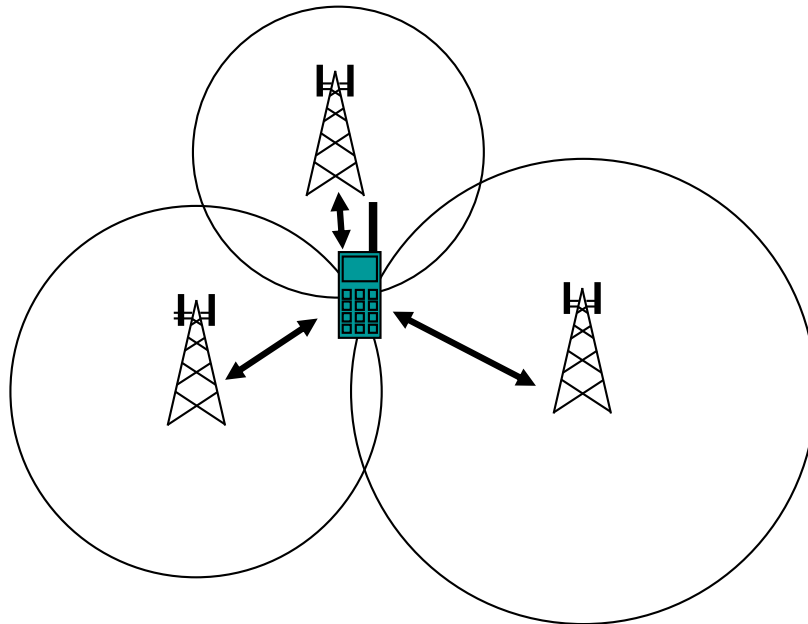

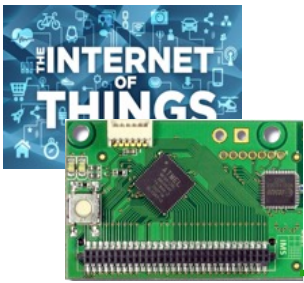

# Mobile devices



## Global Mobile Device Growth by Type By 2019, Smartphones Will Attain Largest Share to Reach Nearly 40%

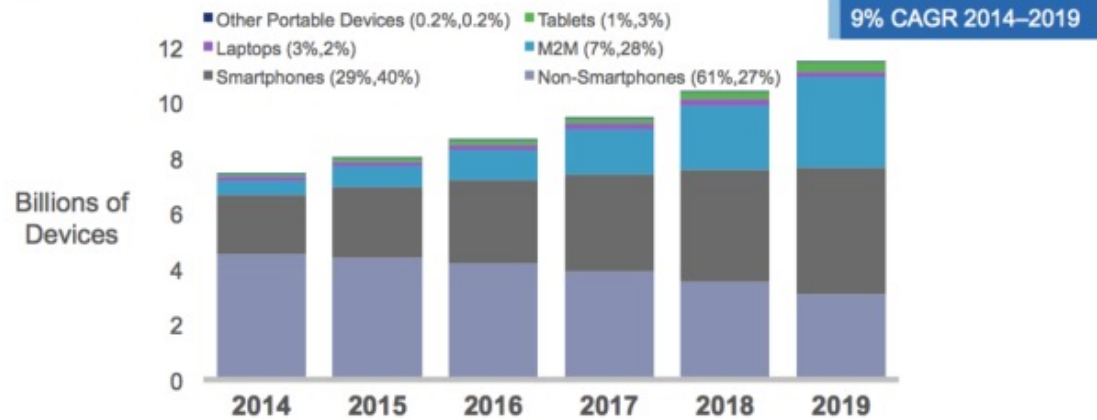

\* Figures (n) refer to 2014 and 2019 device shares

Source: Cisco VNI Global Mobile Data Traffic Forecast, 2014–2019

© 2014 Cisco and/or its affiliates. All rights reserved. Cisco



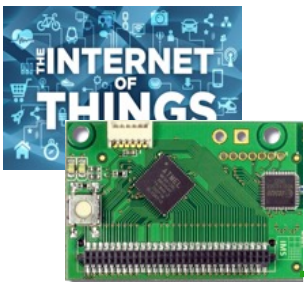

# 5G?

□ A set of objectives, various technologies

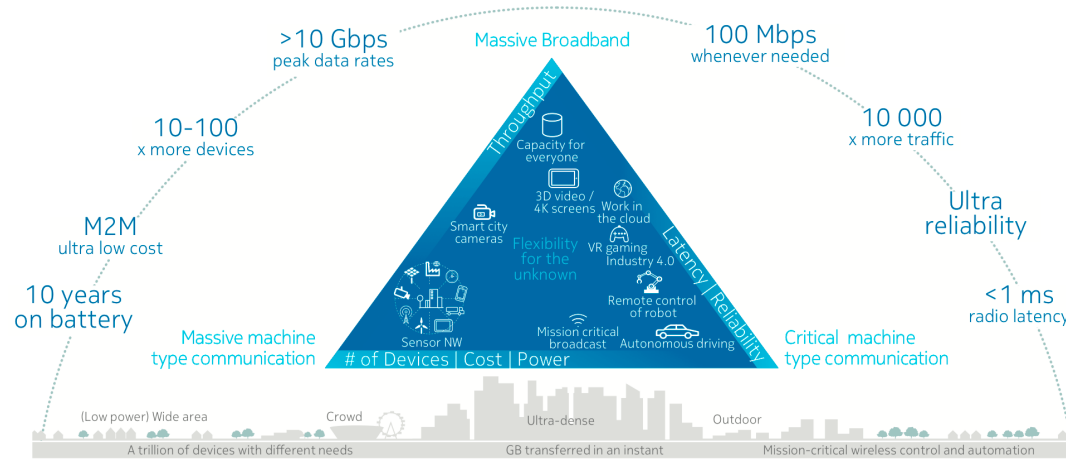
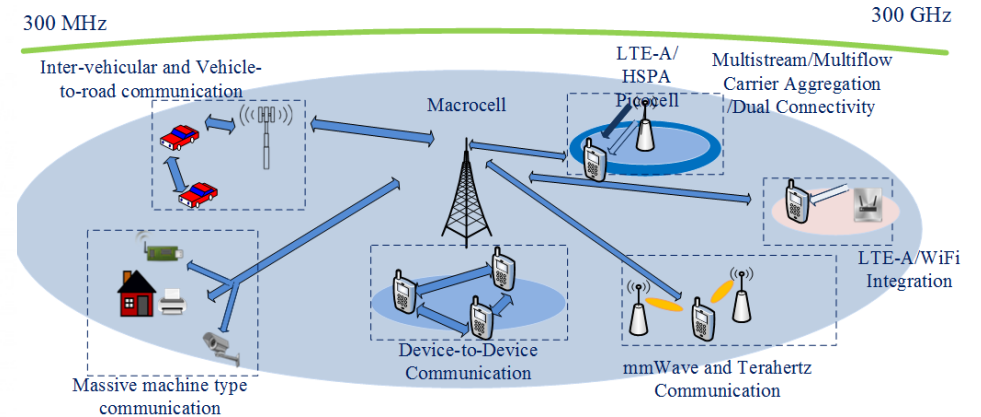
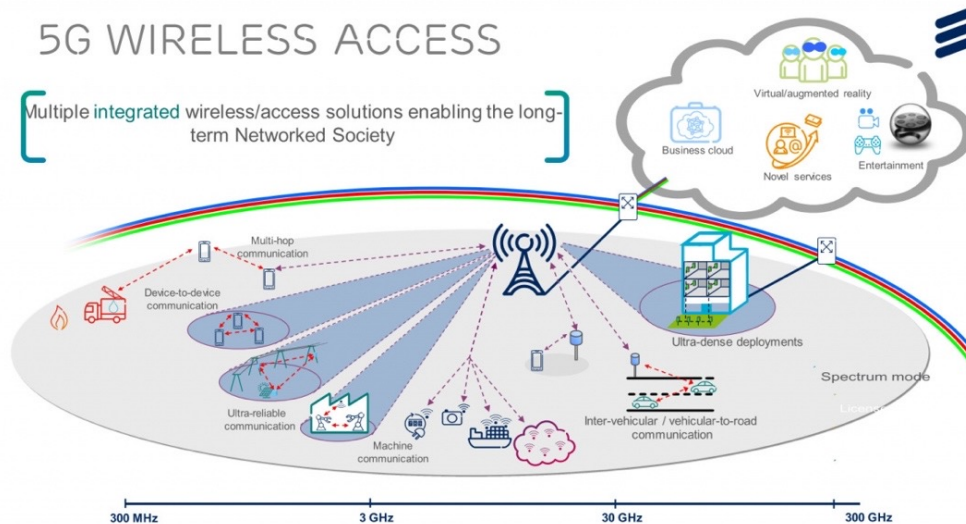
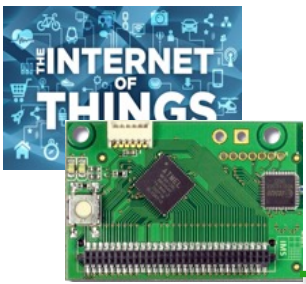

Figure 1. 5G will enable very diverse use cases with extreme range of requirements

## 5G WIRELESS ACCESS

[Multiple integrated wireless/access solutions enabling the long-term Networked Society]





# 5G demo at ITU Telecom World'19

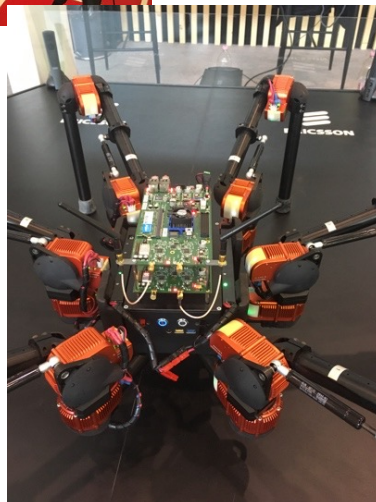

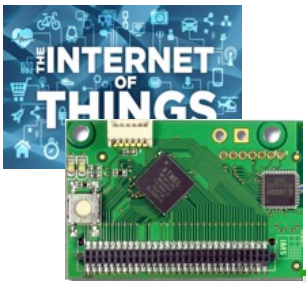

# Internet of Things

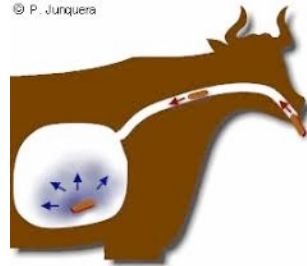
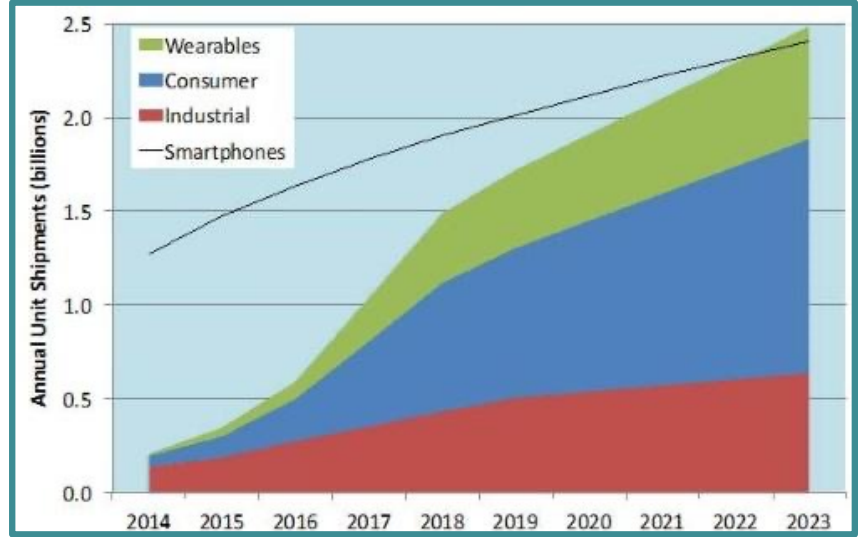

© P. Junquera





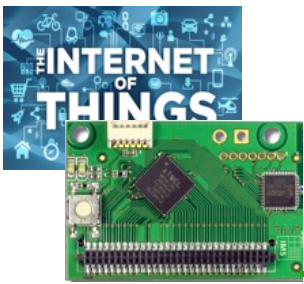

# Connectivity is a challenge

## Internet of Objects 80% of volume



## Requirements:

- How to connect Low Cost Assets or having no Energy source, non rechargeable?
- Low Cost communication
- Low Cost Infrastructure
- Low Power Technology
- Robust Communication
- Allowing Mobility
- Scalability

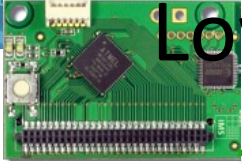

# Low-power & long-range radio technologies

## Energy-Range dilemma

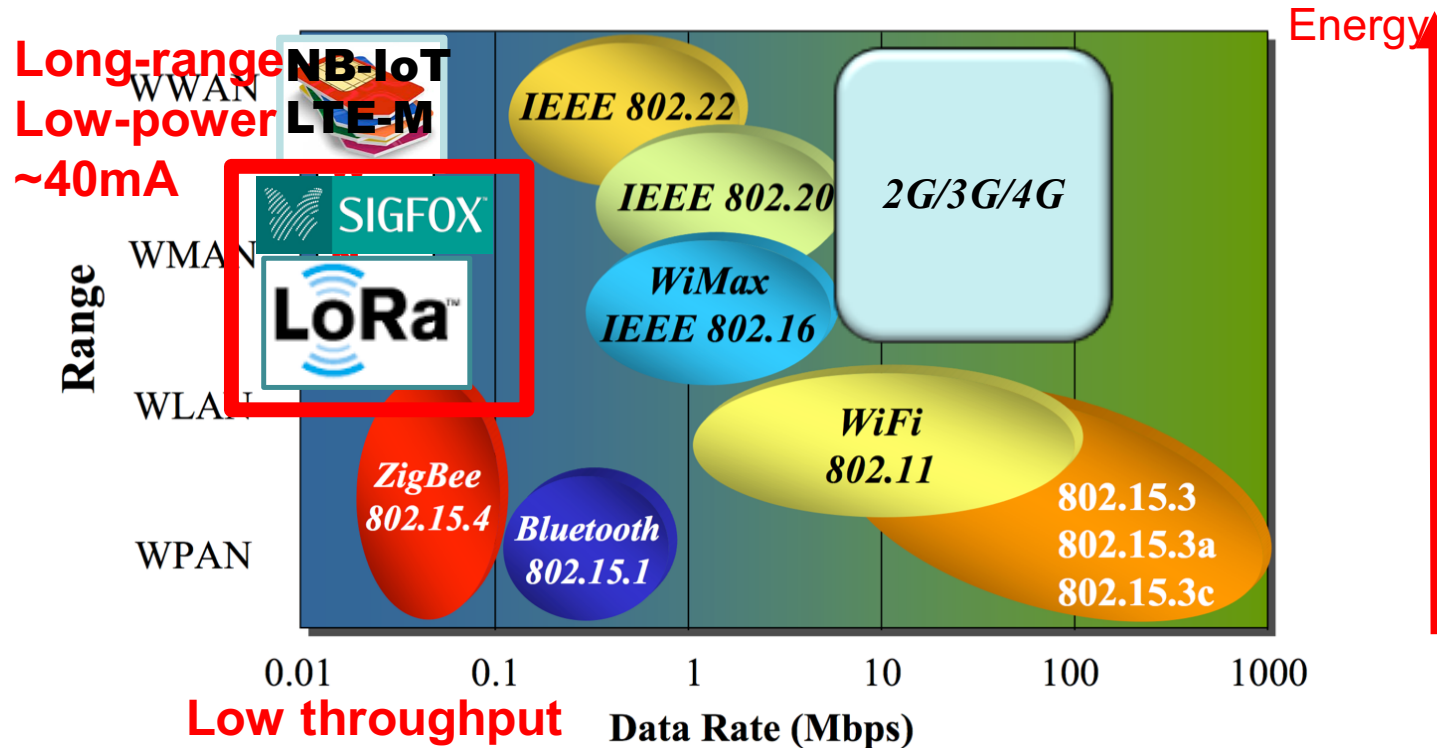

Transmitting: TC/22.5/HUM/67.7 ; about 20 bytes with packet header  
Time on air can be 1.44s with LoRa



# 1-hop: star of star

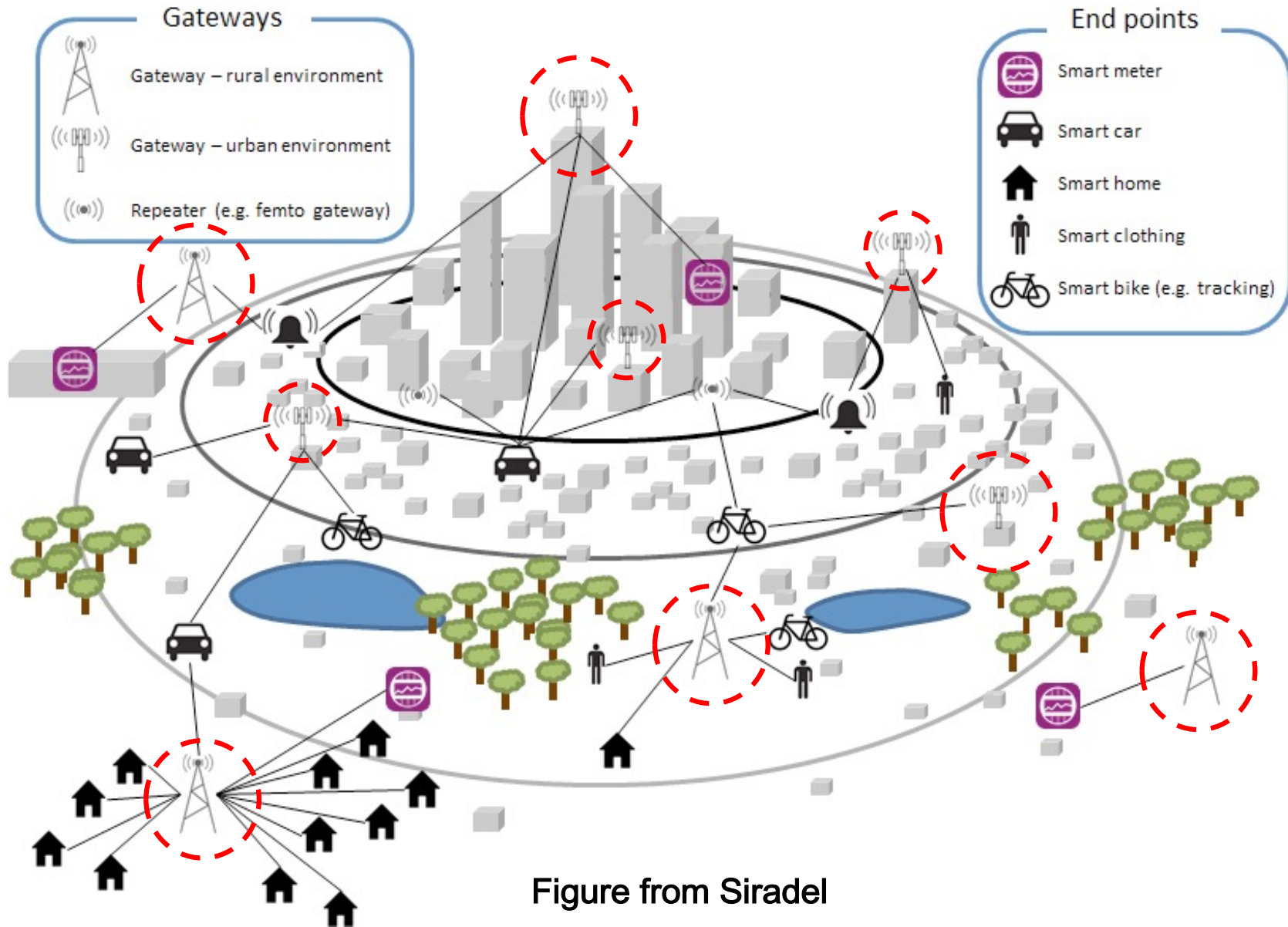
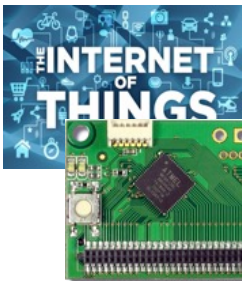
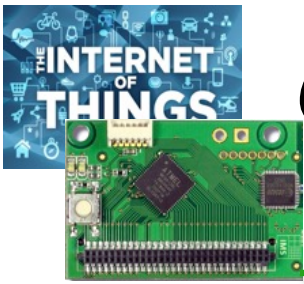

Figure from Siradel



# The network behind the apps/clouds





# Operators and ISPs: they rule the Internet

- ❑ « 1st tier ISP » own their lines.
- ❑ Interconnections happen mostly at private peering points

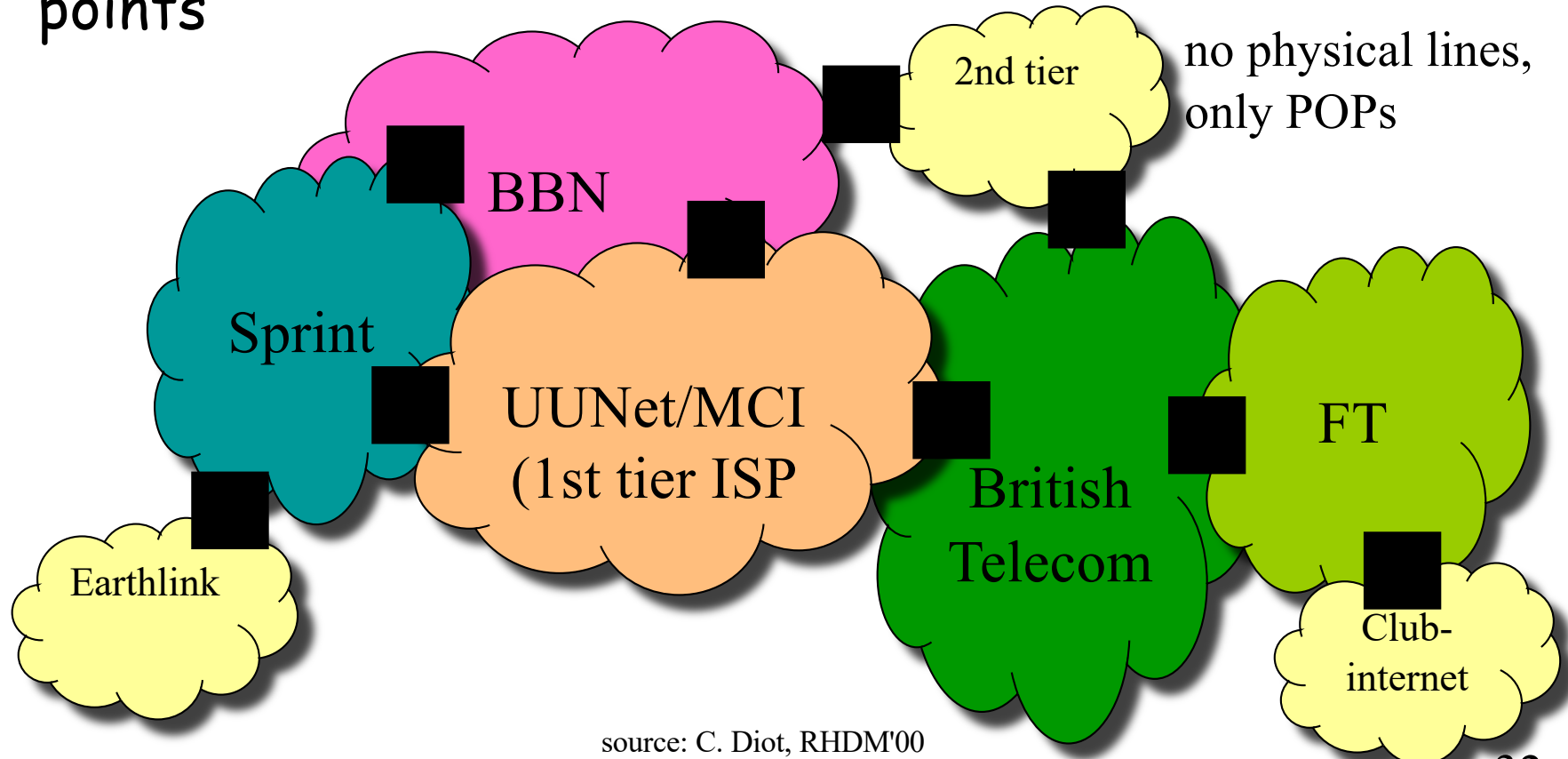

source: C. Diot, RHDM'00

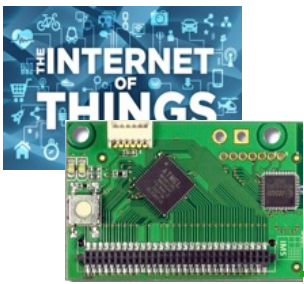

# Back in time: The telephone system & network

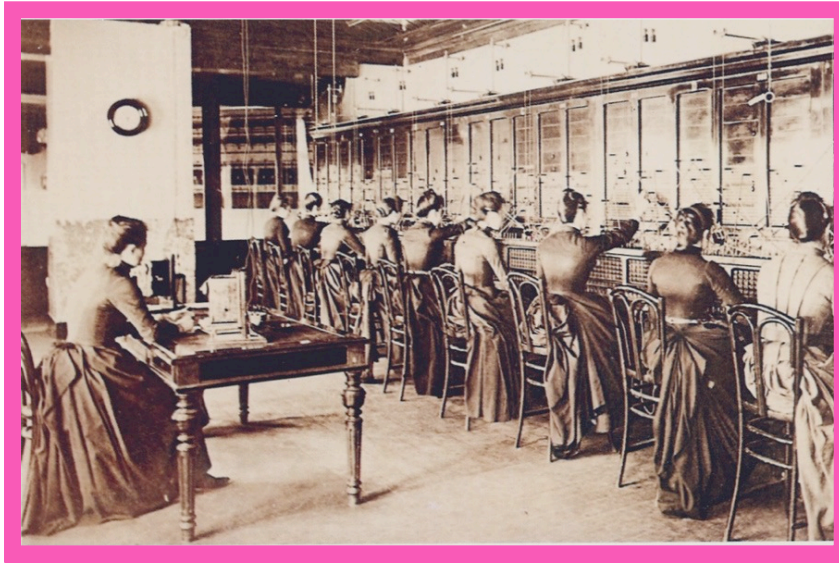

**Signaling replaces the  
operator**



*First automatic Branch Exchange Almond  
B. Strowger, 1891...*

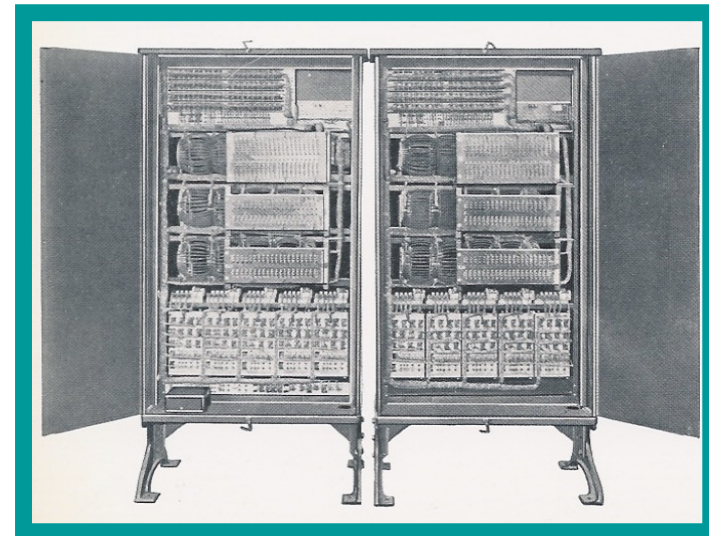

Source J. Tiberghien, VUB

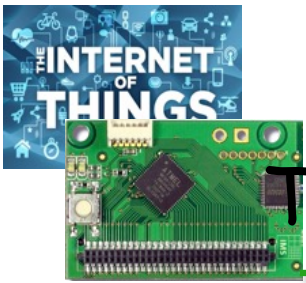

# Back in time: The telephone network, E.164 addressing

## Analog / Digital

Source J. Tiberghien, VUB

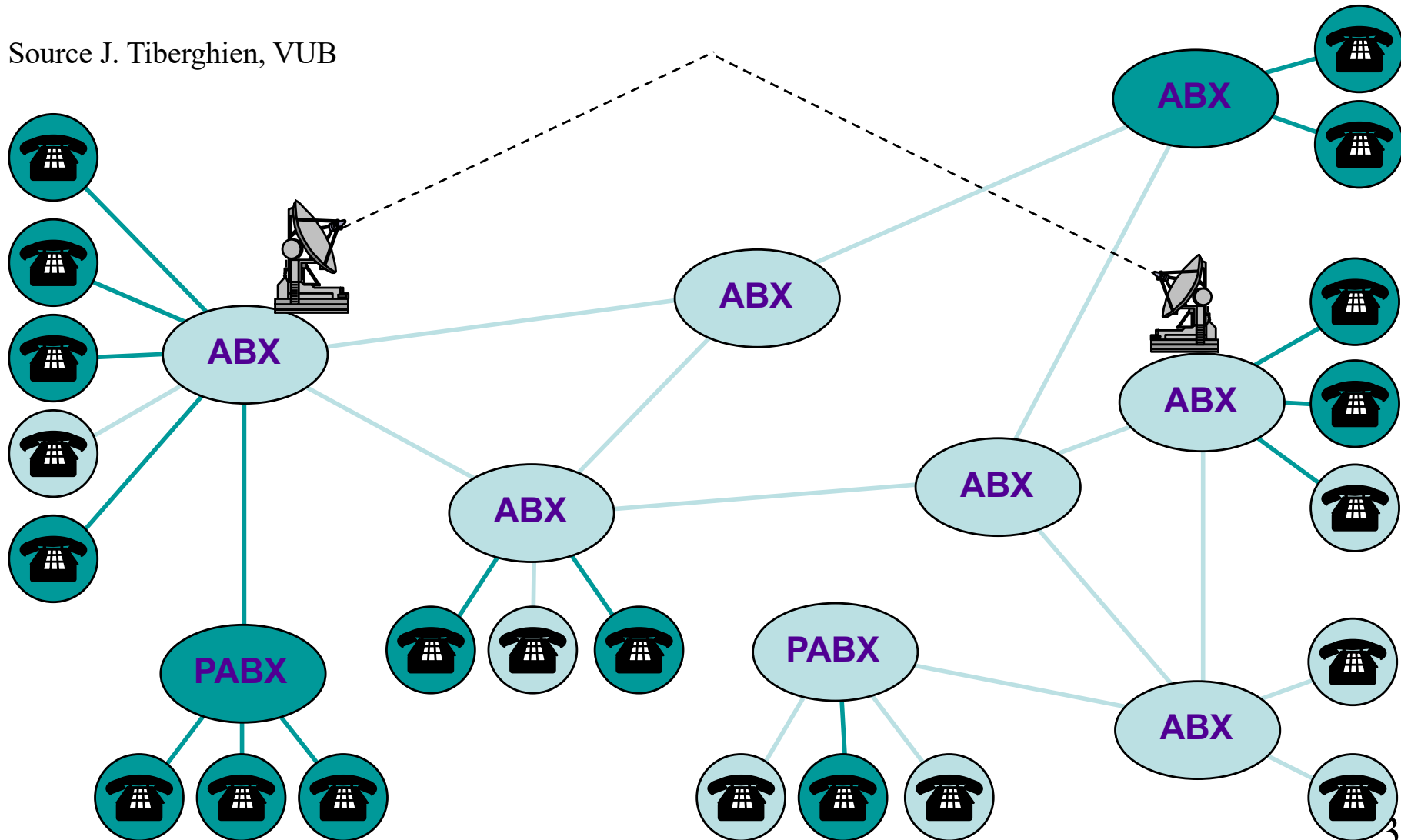



# Close-up on accesses

Source J. Tiberghien,

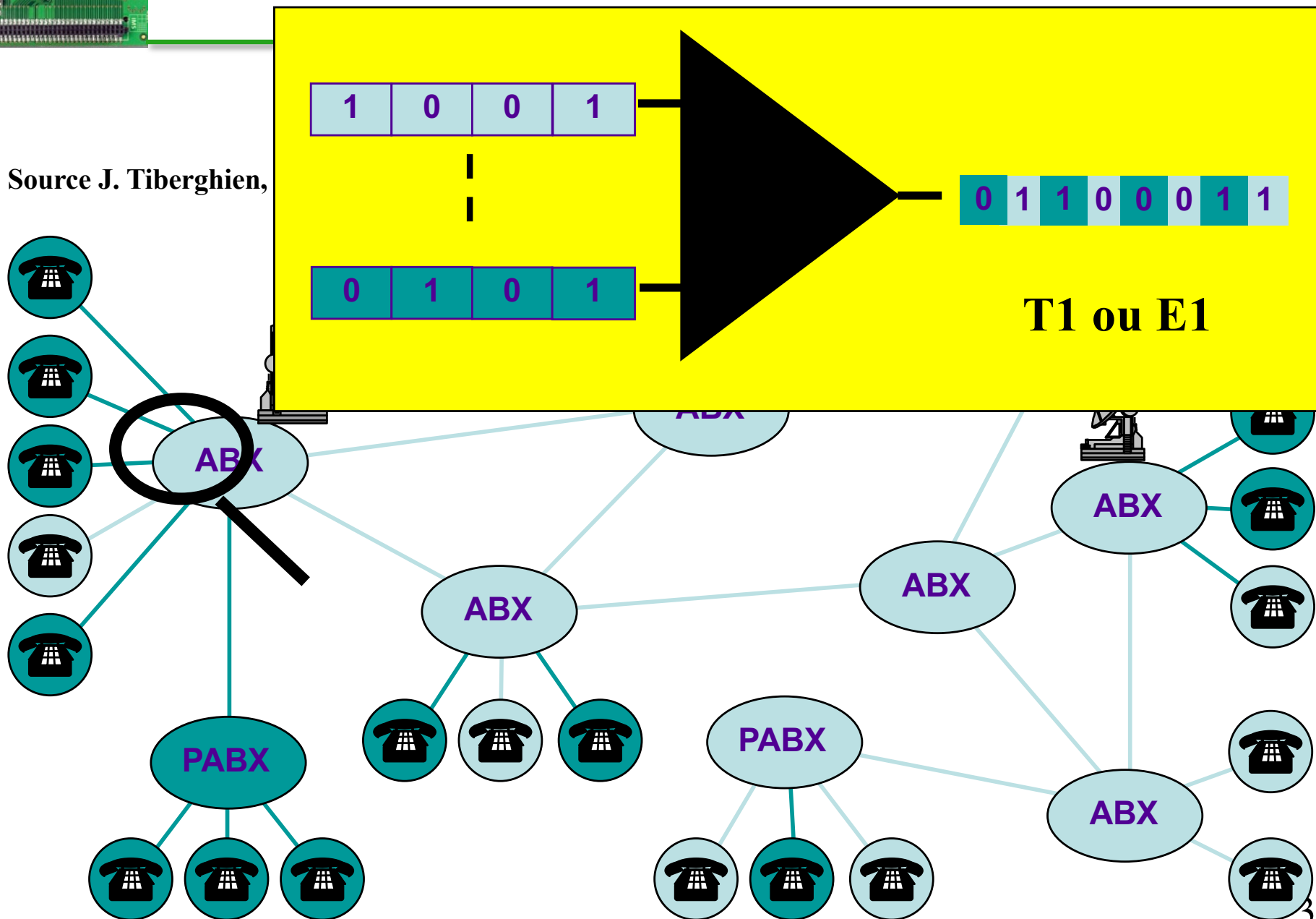



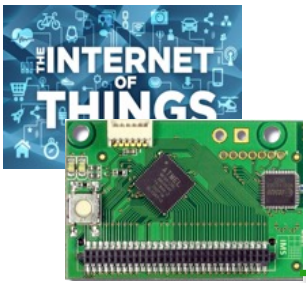

# Analog voice to digital voice

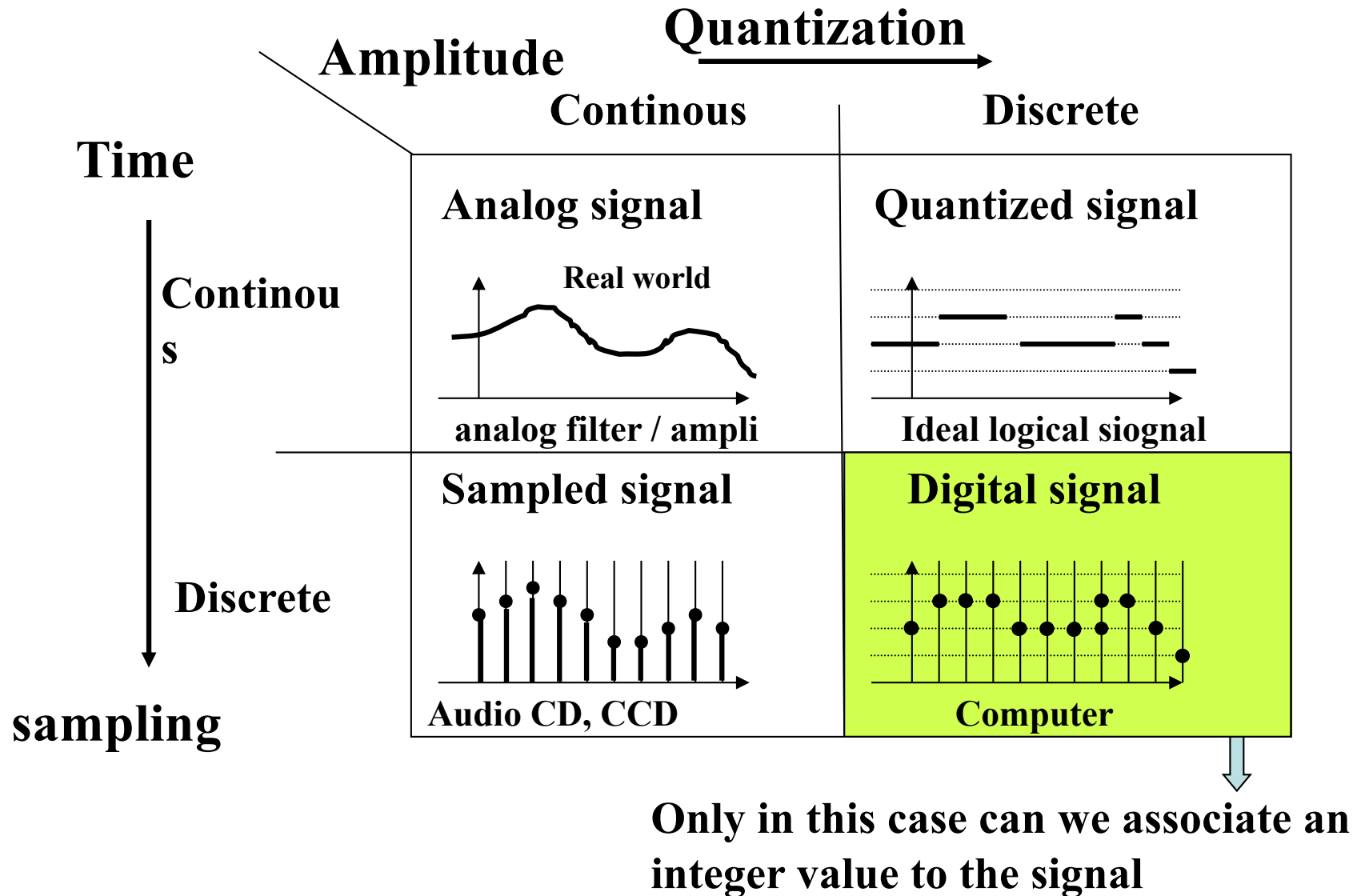



# Bell D2 system (DS1/T1) (CCITT G733)

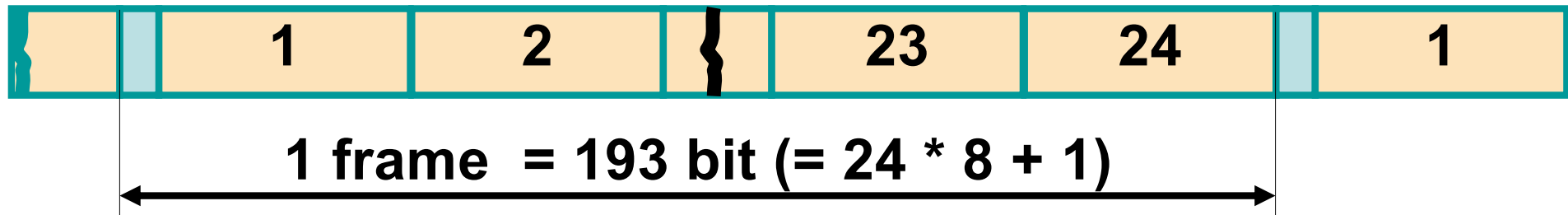

Frame duration :	125 $\mu$ S	= 1 / 8000
Number of channels :	24	
Frame length :	193 bit	= 8 * 24 + 1
Bit frequency :	1544 kHz	= 193 / 125.10 <sup>-6</sup>
Signaling :	least significant bit stolen once every 6 frames	
Signaling rate :	1.3 kb/s	= 8000 / 6
Frame synchronization by bit 0		



# CEPT 30 (E1) (CCITT G732)

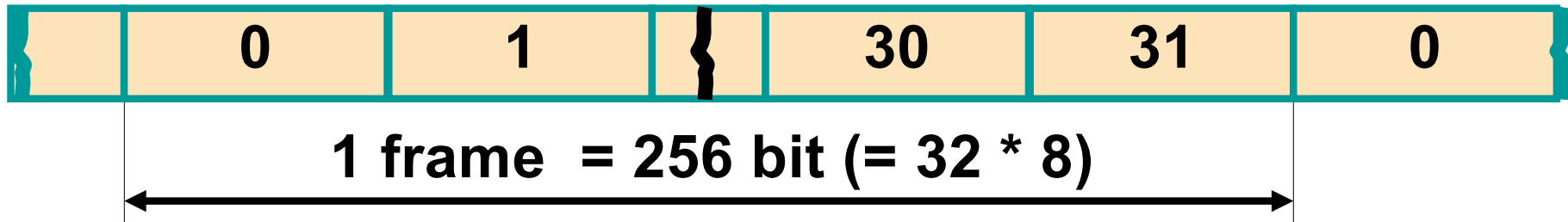

Frame duration :	125 $\mu$ S	= 1 / 8000
Number of channels :	30	
Frame length :	256 bit	= 8 * 32
Bit frequency :	2048 kHz	= 256 / 125.10 <sup>-6</sup>
Signaling :	Slot 16 reserved	
Channel Signaling :	2 kb/s	= 64 / 32 kb/s
Common Signaling :	64 kb/s	
Frame sync. and link management by slot 0		

**T1/E1 represents the main underlying technologies for dedicated leased lines: Transfix in France for example  
Bandwidth from 2400bps to 45Mbps  
(T3 in US)**

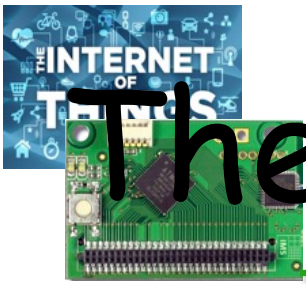

# The telephone circuit view

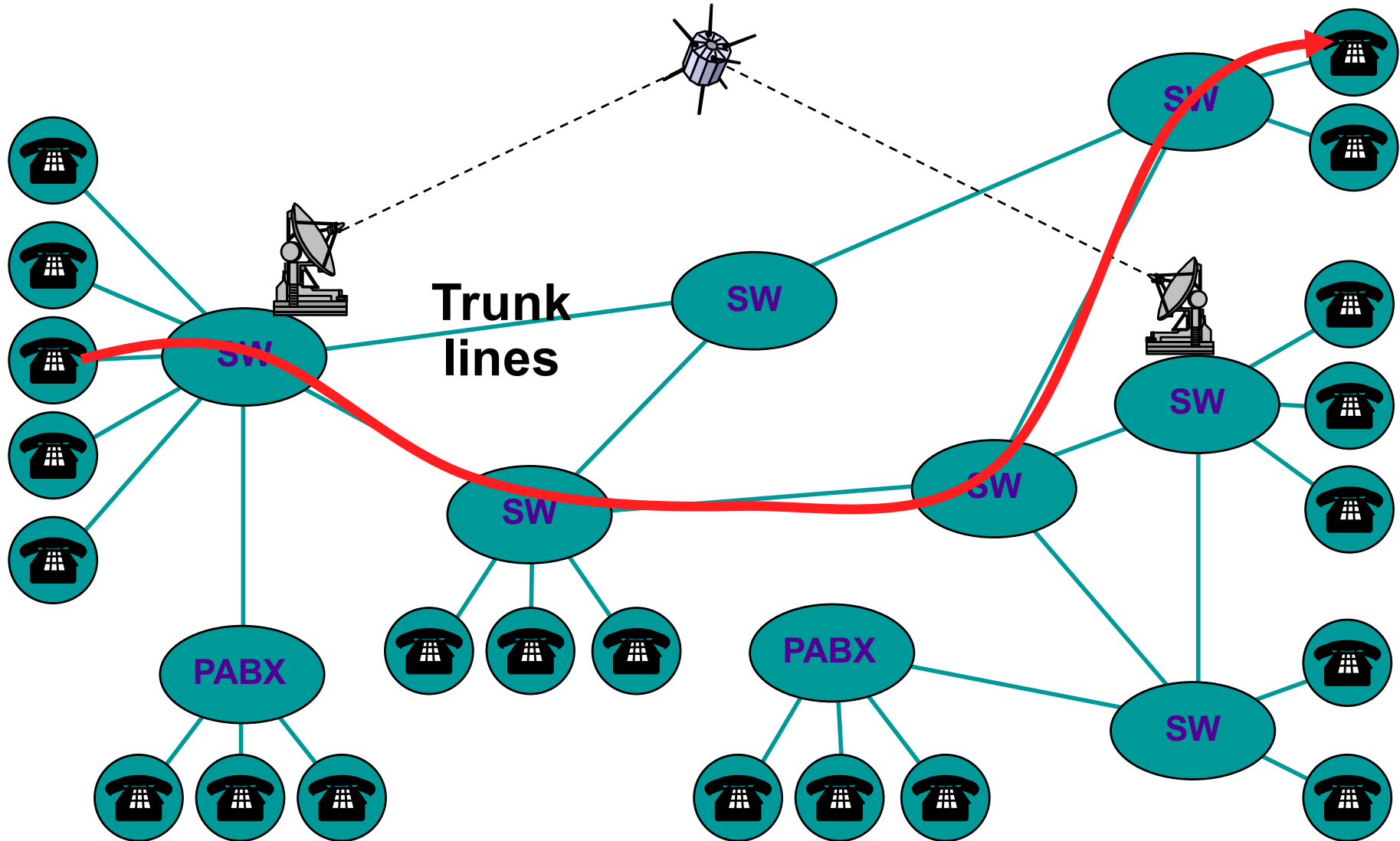



# Advantages of circuits

---

- ❑ Provides the same path for information of the same connection: less out-of-order delivery
- ❑ Easier provisioning/reservation of network's resources: planning and management features

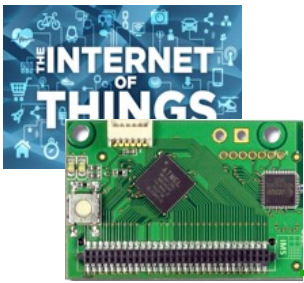

# Time Division Circuits

- ❑ Most trunks time division multiplex voice samples
- ❑ At a central office, trunk is demultiplexed and distributed to active circuits
- ❑ Synchronous multiplexor
  - ❑ N input lines
  - ❑ Output runs N times as fast as input

Simple, efficient, but low flexibility and wastes resources

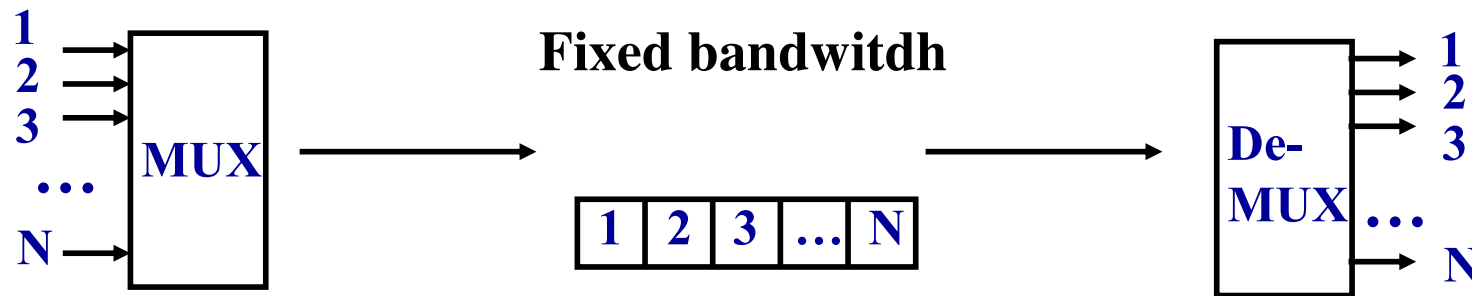

1 sample every 125us gives a 64Kbits/s channel



# Plesiochronous Digital Hierarchy

---

- ❑ Digital lines have been replacing analog lines, but not in one day!
- ❑ Timing amongst these lines is not perfect!
- ❑ PDH uses more throughput in the output to accommodate these not synchronized signals
- ❑ Problem is when demultiplexing the signal



# PDH, no synchronism

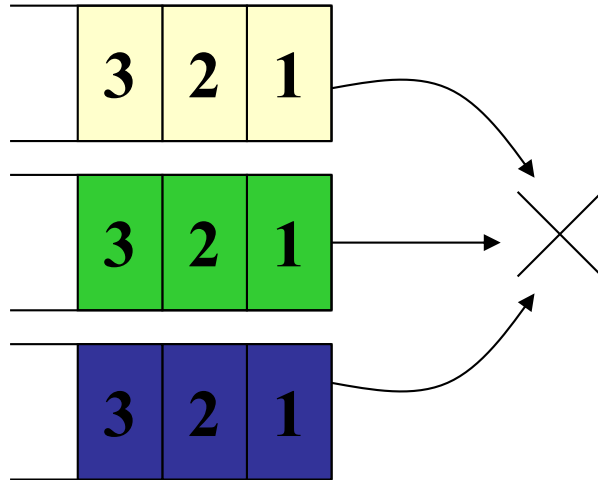

## Synchronism

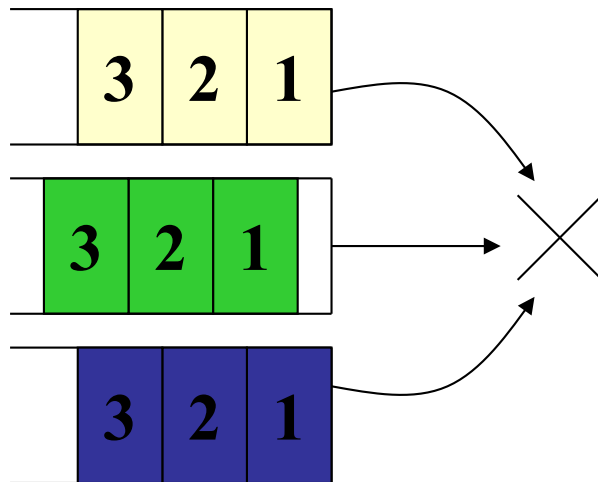
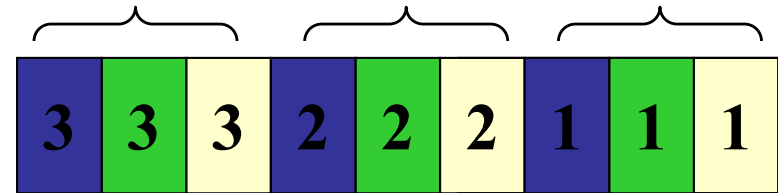

## Padding bytes

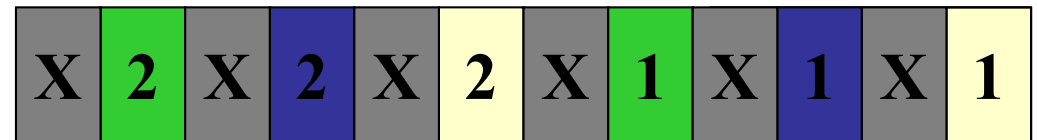



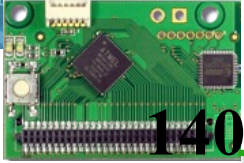

# PDH: Add Drop Multiplexer

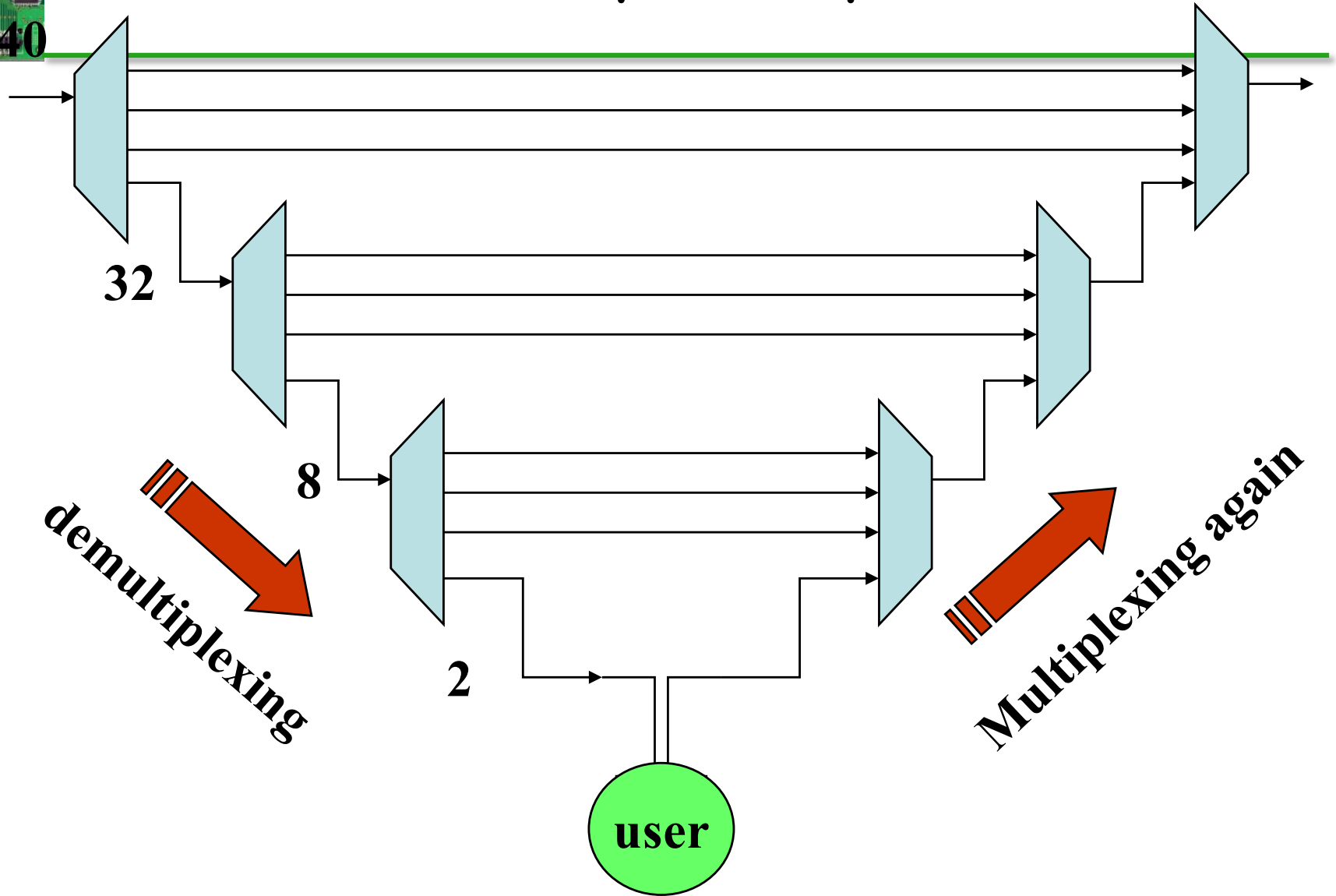

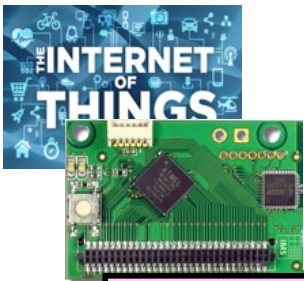

# Digital Telephony in 1984

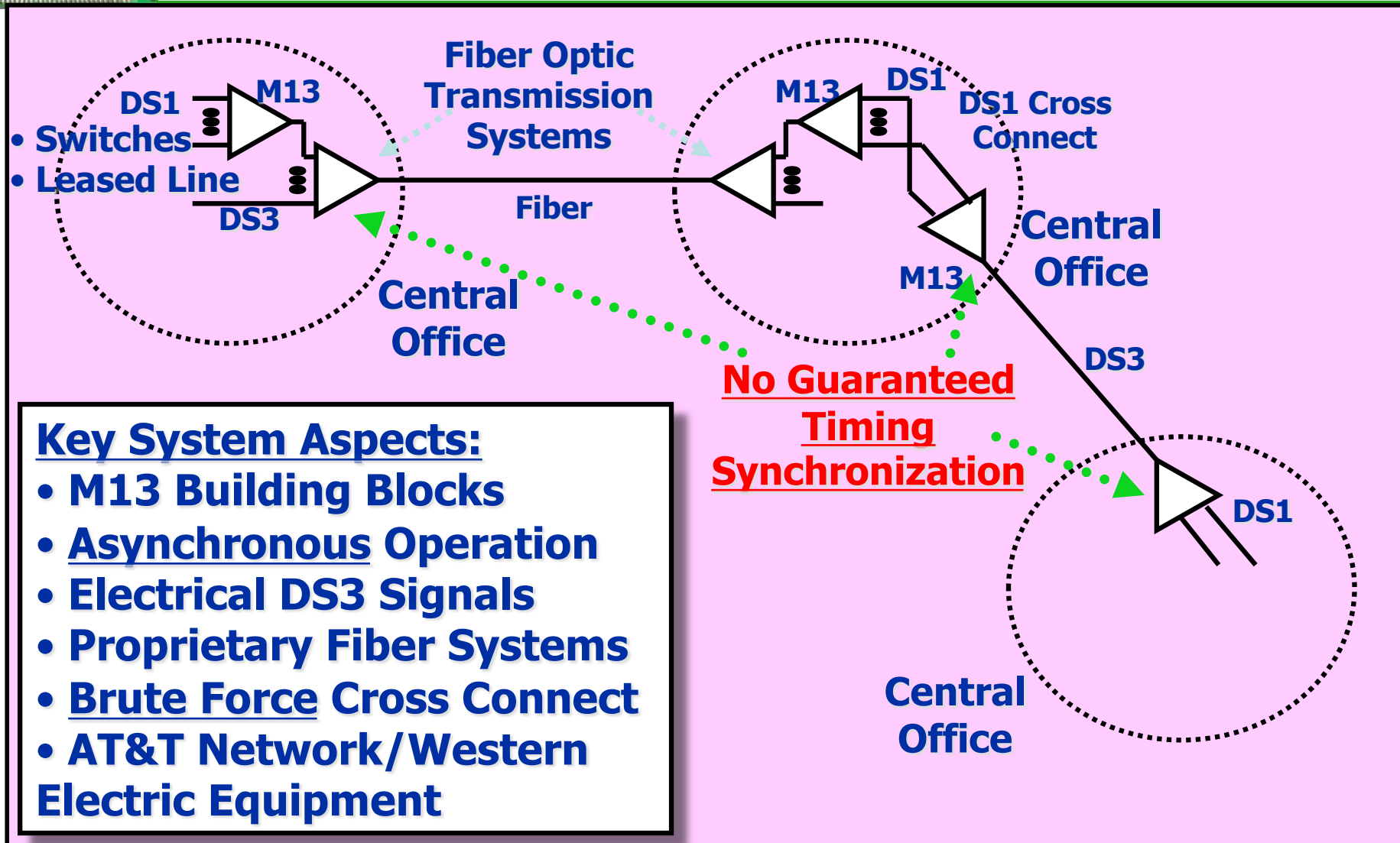



# Post-AT&T Divestiture Dilemmas

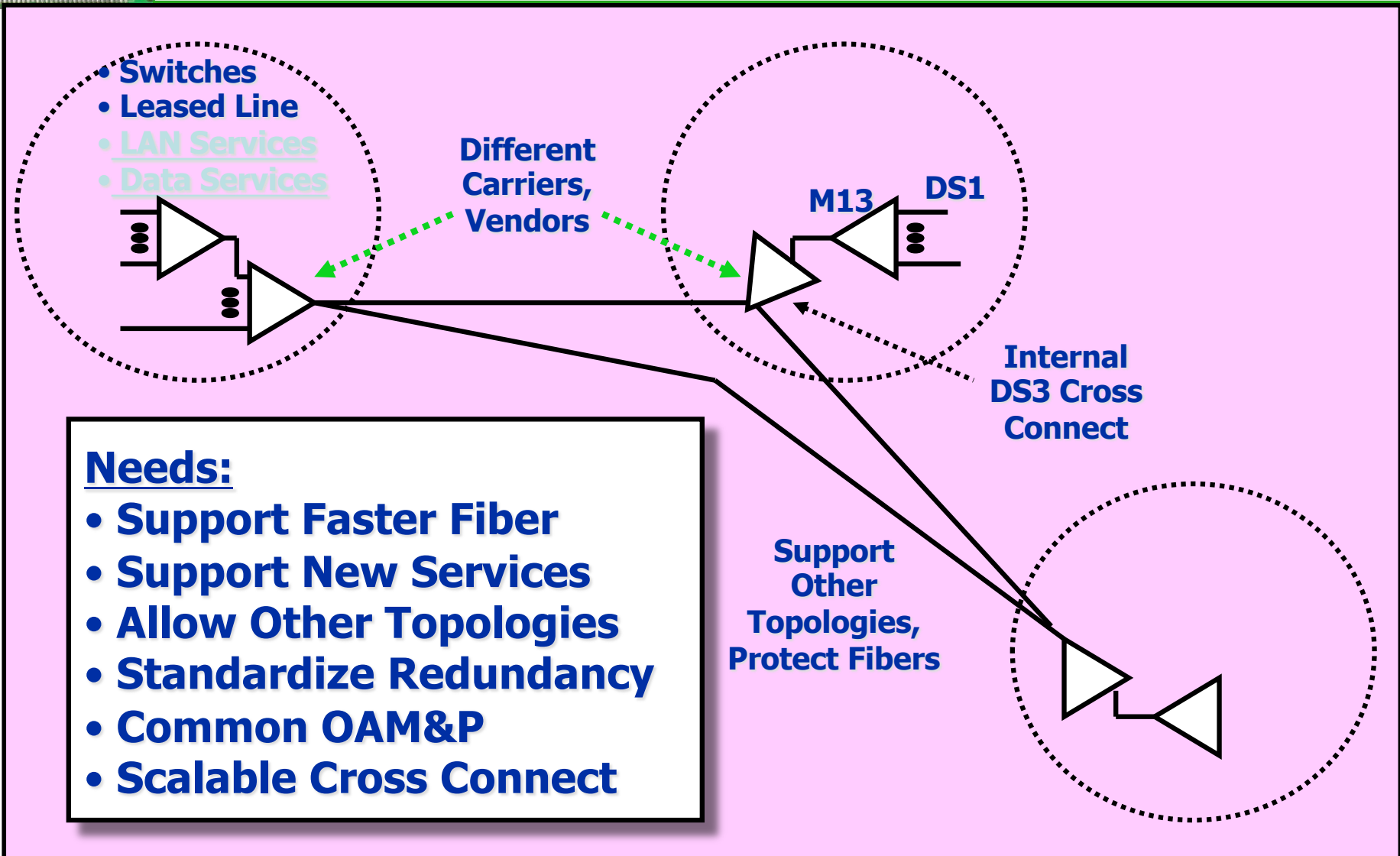



# The core networks and SONET/SDH

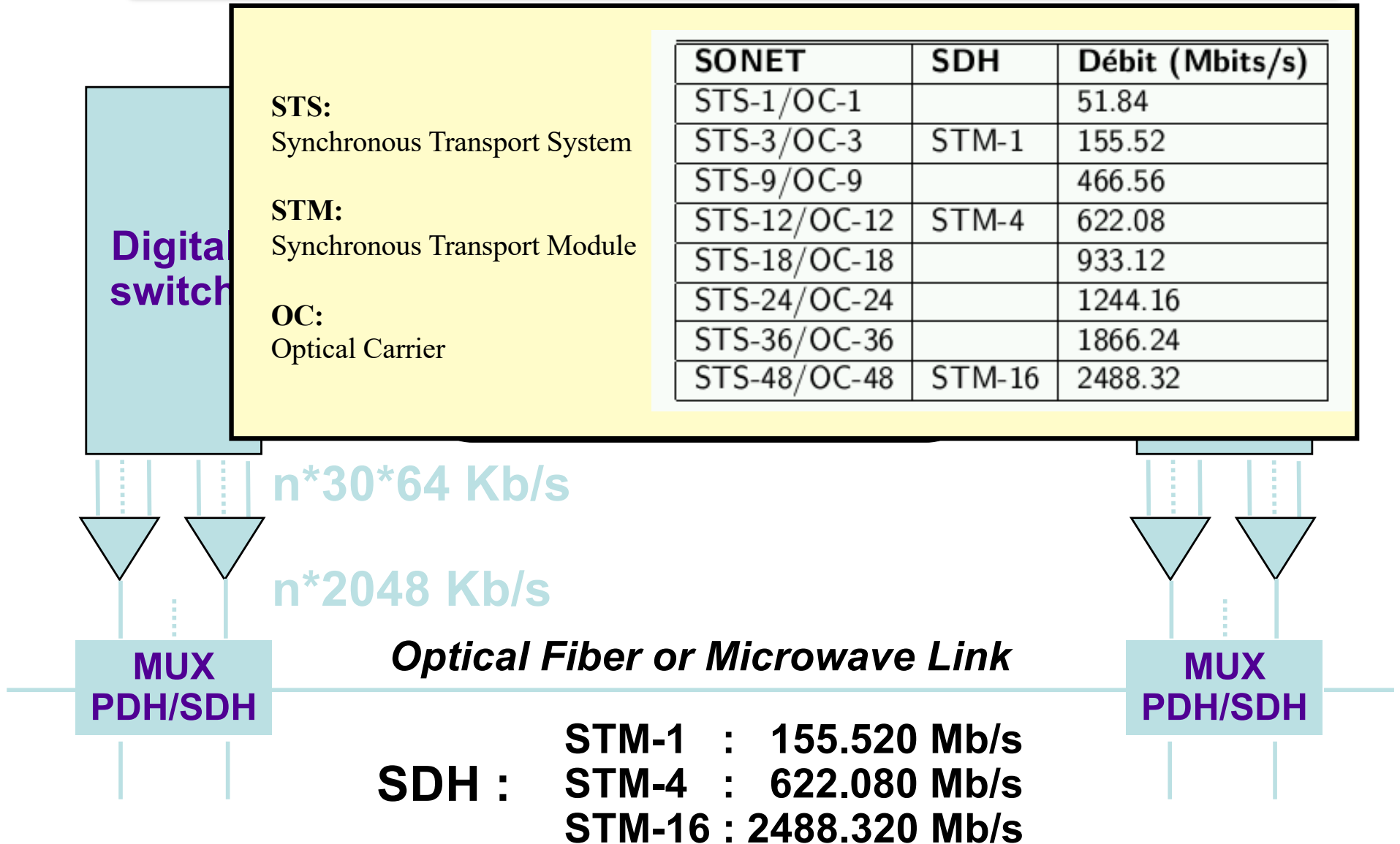



# The SONET frame

- ❑ Basic frame length is 810 bytes
  - ❑ Sent every 125us, raw throughput of 51.84 Mbits/s (STS-1)
  - ❑ Better seen as a block with 90 columns and 9 lines
  - ❑ SDH has STM-1 which corresponds to an STS-3

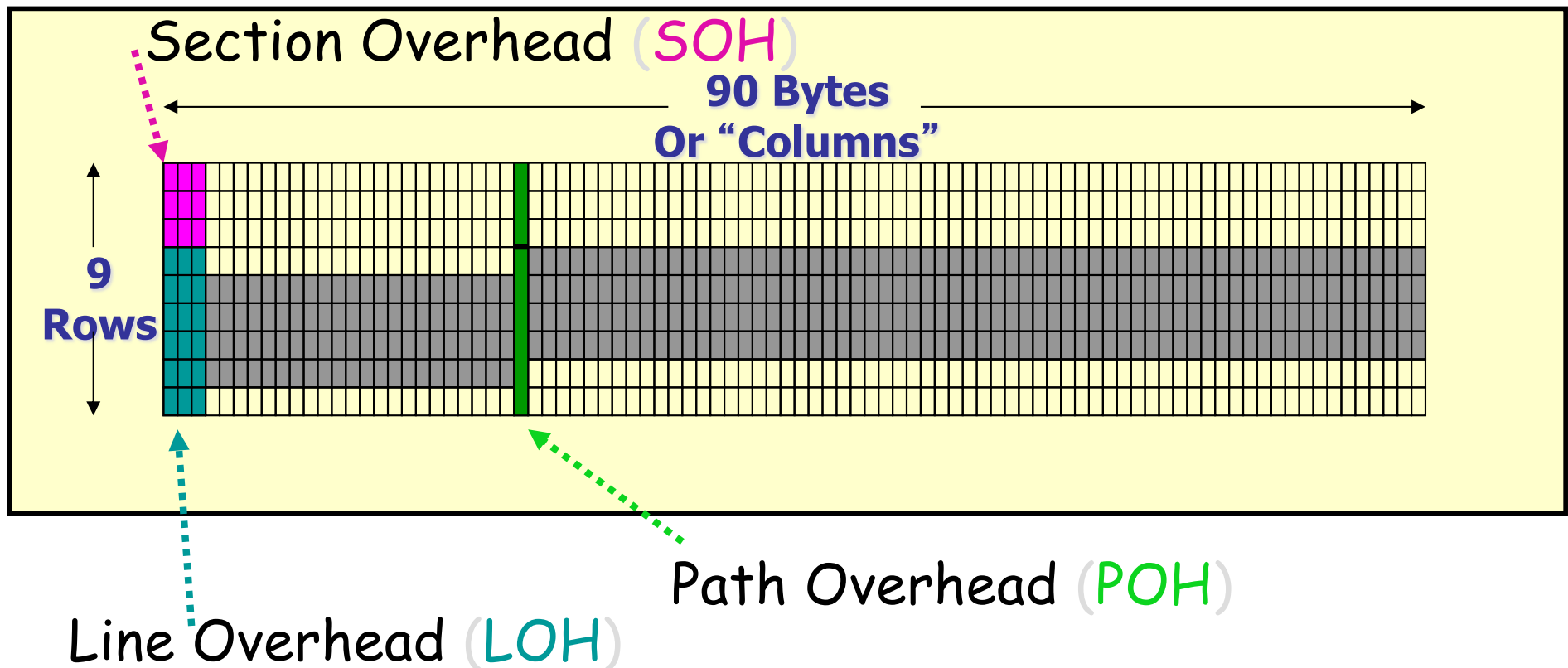

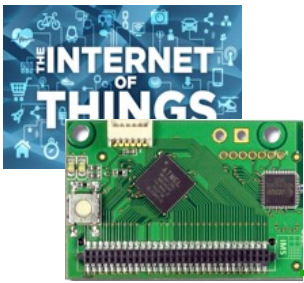

# SONET/SDH transport network infrastructure

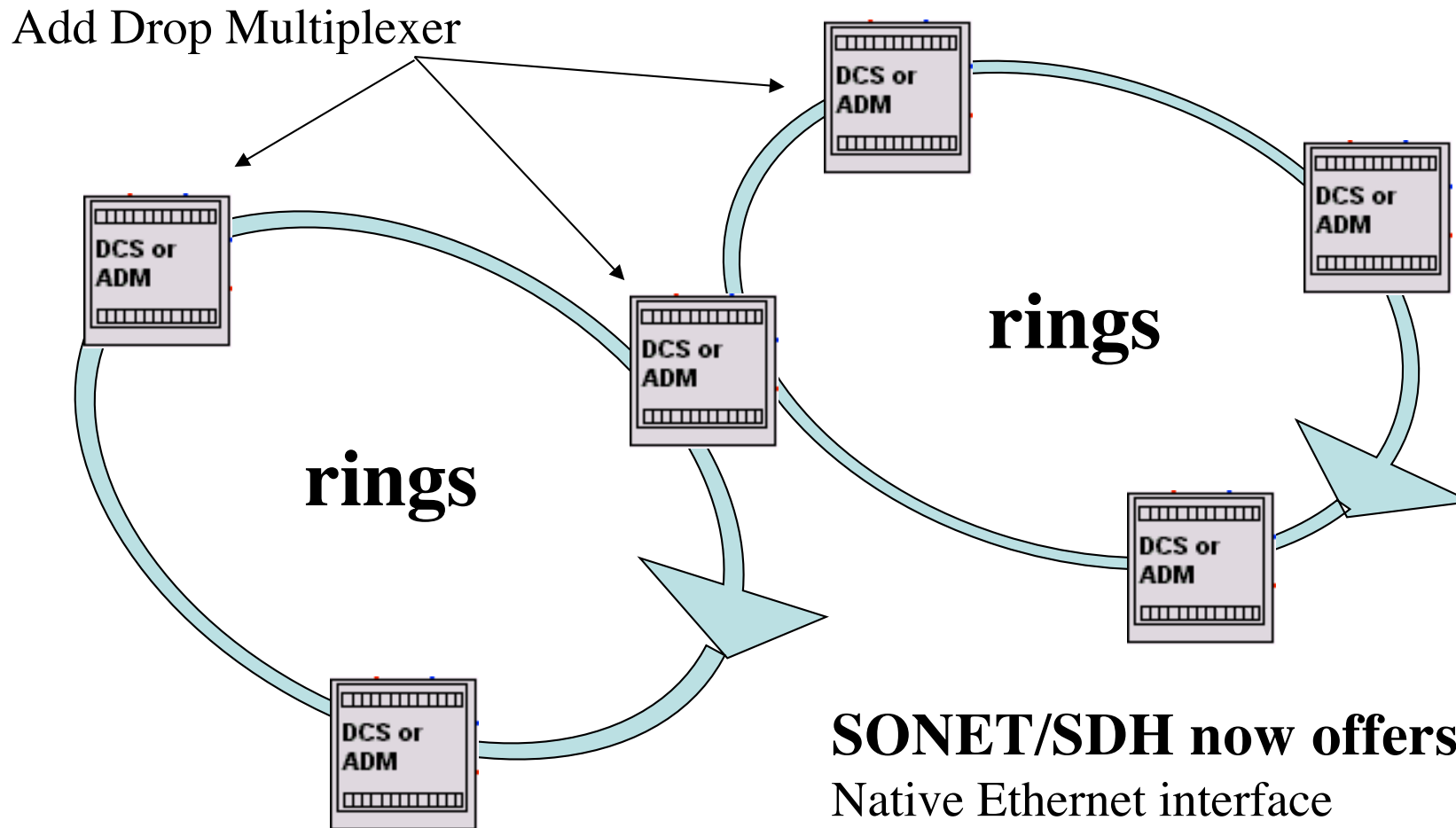

**SONET/SDH now offers**  
Native Ethernet interface  
Generic Framing Procedure  
Virtual Concatenation

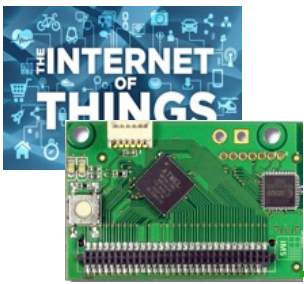

# SONET/SDH and resiliency

- SONET/SDH has built-in fault-tolerant features with multiple rings
- Ex: simple case

DCS  
(Digital Cross-Connects)

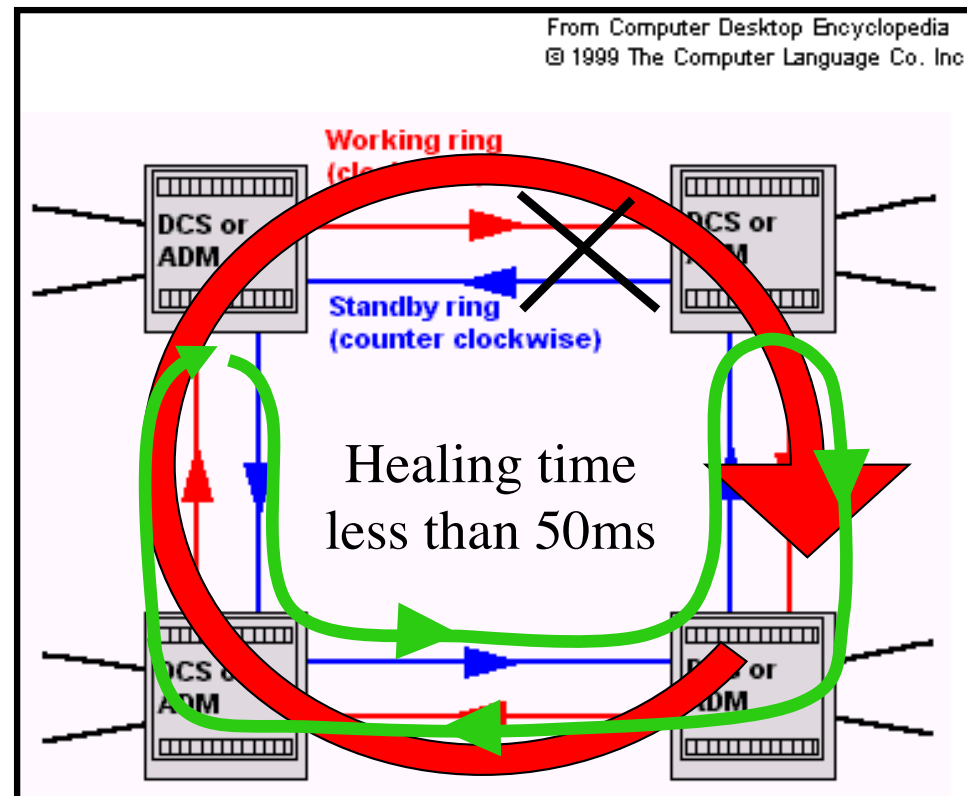

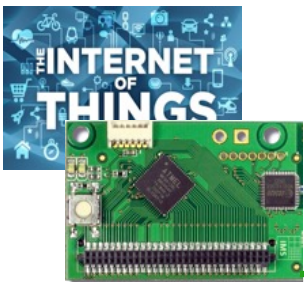

# SONET/SDH and resiliency

From Computer Desktop Encyclopedia  
© 1999 The Computer Language Co. Inc.

From Computer Desktop Encyclopedia  
© 1999 The Computer Language Co. Inc.

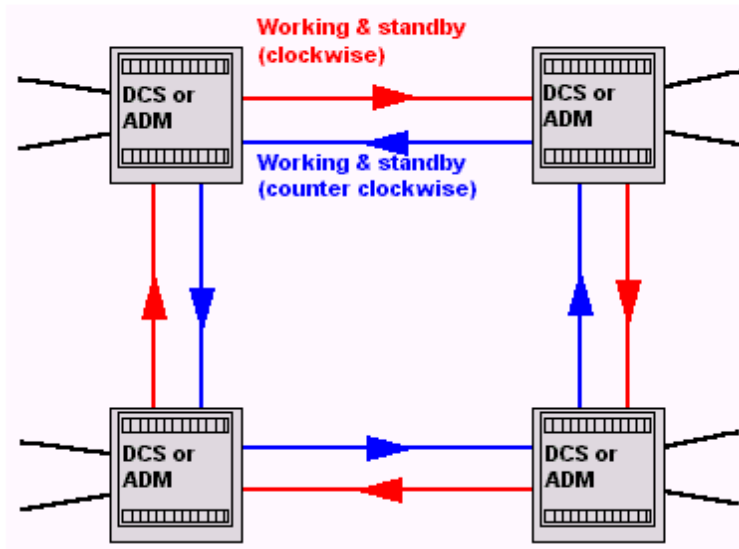

bi-directional

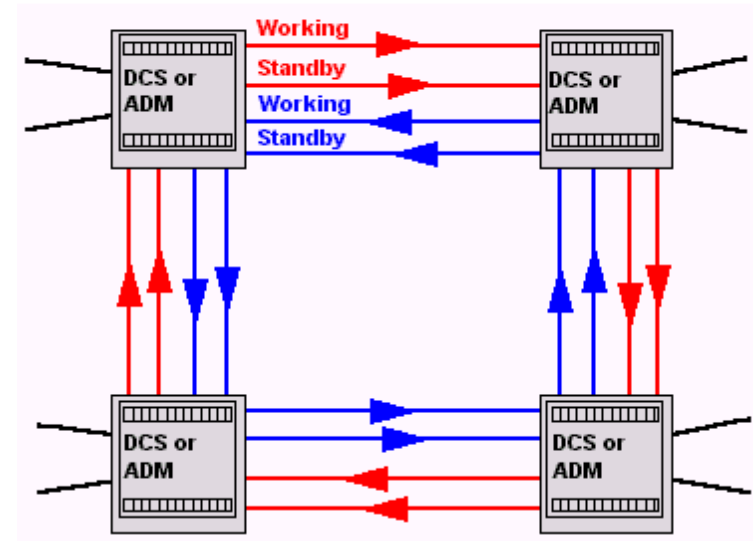

Found in most operators



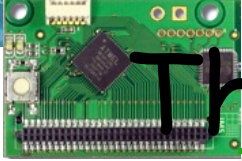

# SDH Rings

## The Worldcom Belgian Network

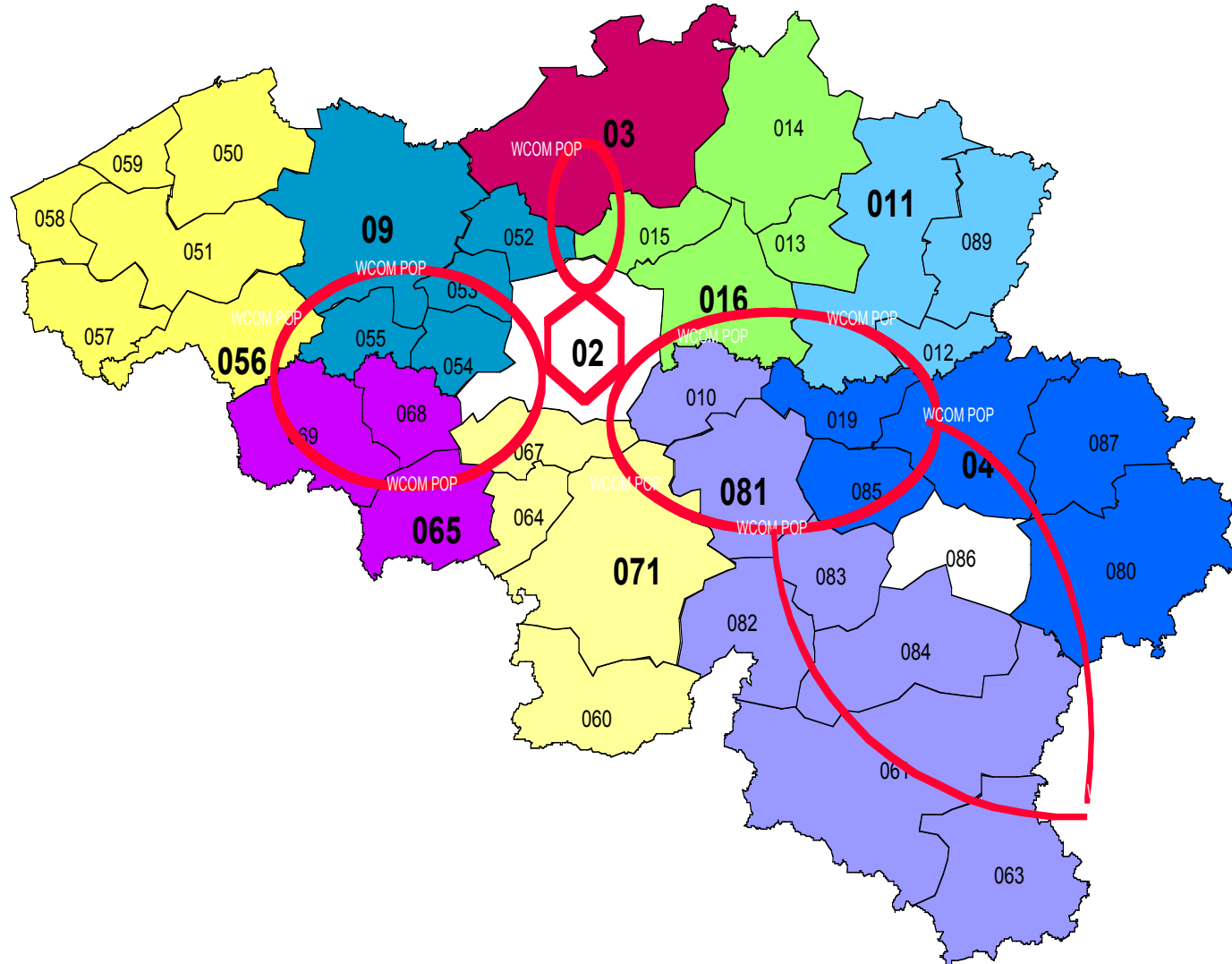



# Merging IP networks and telco networks

---

- We saw:
  - The architecture of the Internet
  - The architecture of telco networks
- How these 2 types of networks interoperate?
  - Where?
  - With which technologies?

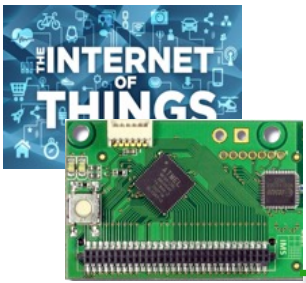

# Example: IP networks

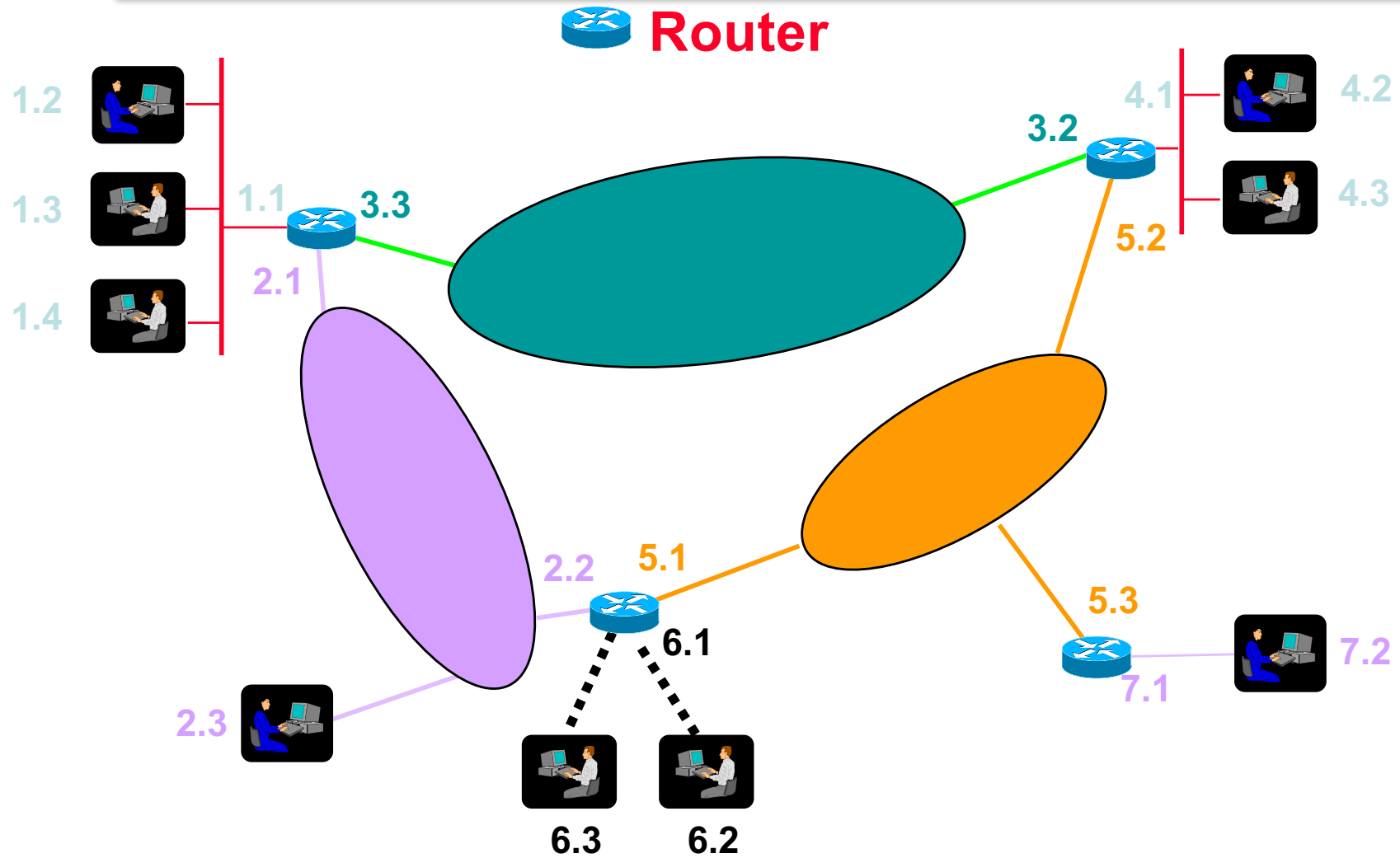



# Directly linked Routers

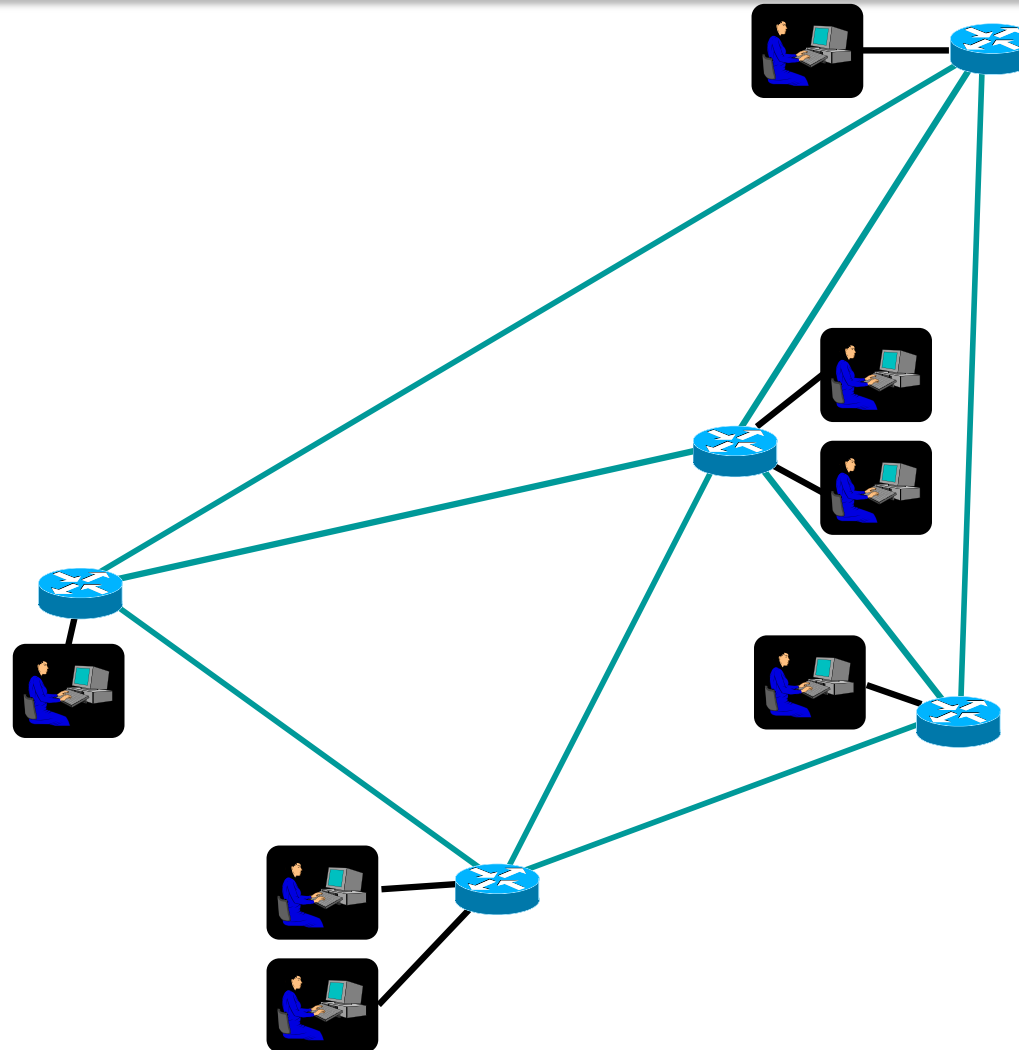

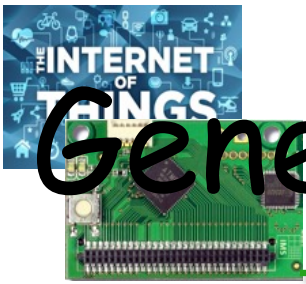

# General Purpose SDH Networks

NG SONET/SDH now offers  
Native Ethernet interface  
Generic Framing Procedure  
Virtual Concatenation

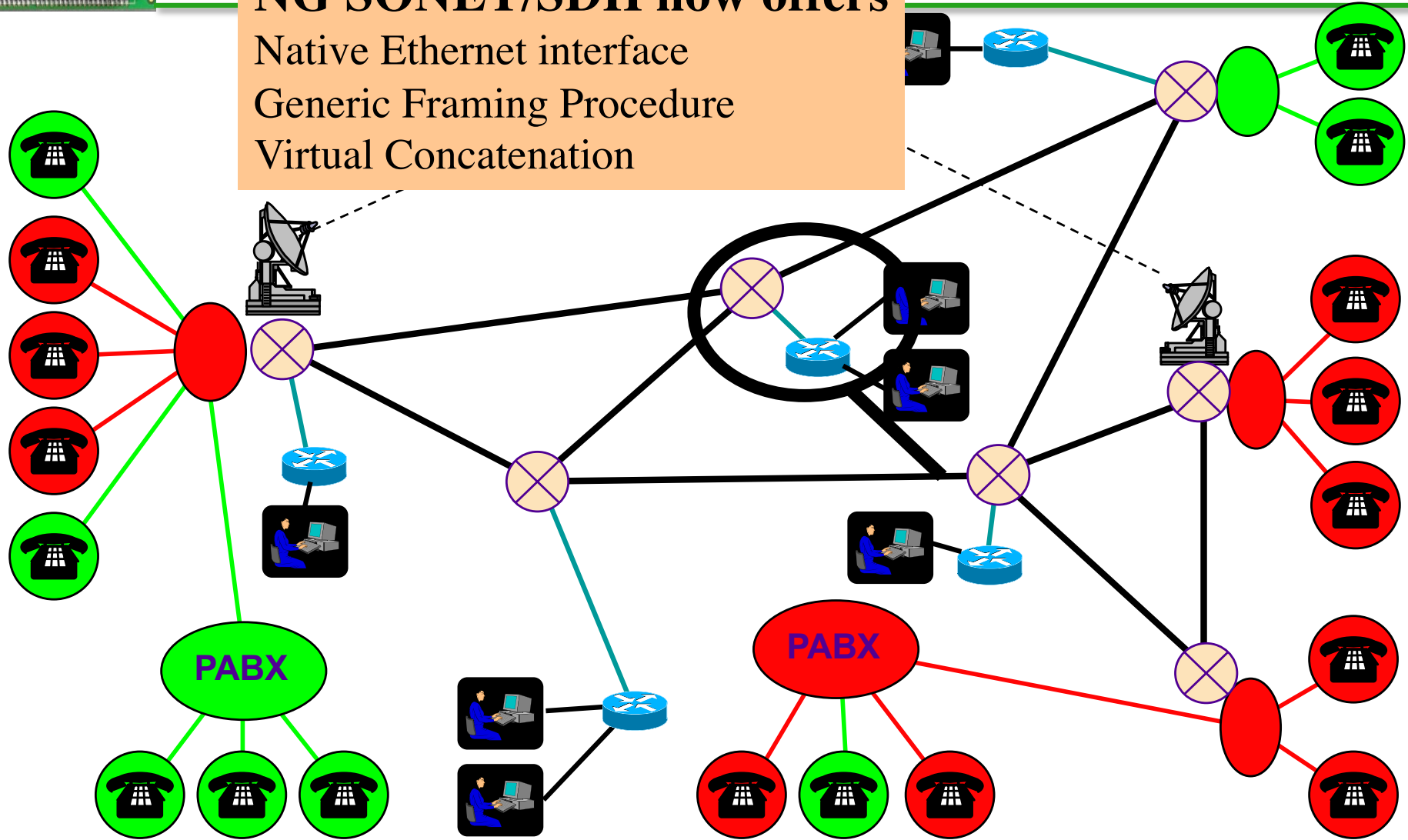



# The world is high-speed!

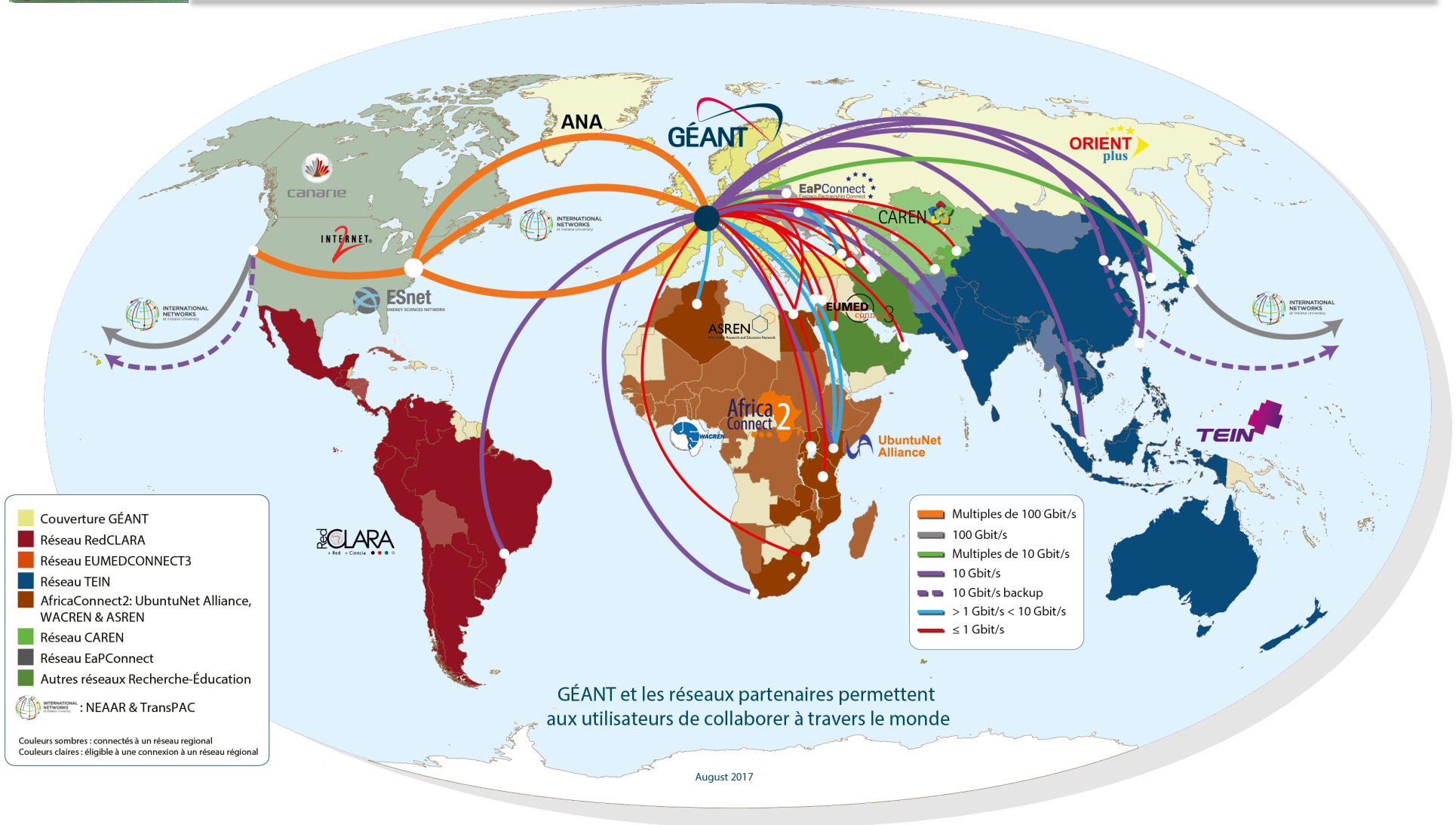



# Is it really?





# What is Quality of Service?



- ❑ Quality of service is the ability to provide different priority to different applications, users, or data flows, or to guarantee a certain level of performance
- ❑ QoS criteria are numerous and is highly dependant of the app.
  - ❑ Throughput, Delay, jitter, Loss rate, Availability, Uptime, ...
- ❑ ... Or driven by the end-user
  - ❑ Image resolution, sound quality, appropriate language, ...



## What is QoS (contd) ?

- ❑ These parameters can be measured at several granularities:
  - ❑ “micro” flow, aggregate flow, population.
  
- ❑ QoS considered “better” if
  - ❑ more parameters can be specified
  - ❑ QoS can be specified at a fine-granularity.
  
- ❑ QoS spectrum:

**Best Effort**

**Leased Line**

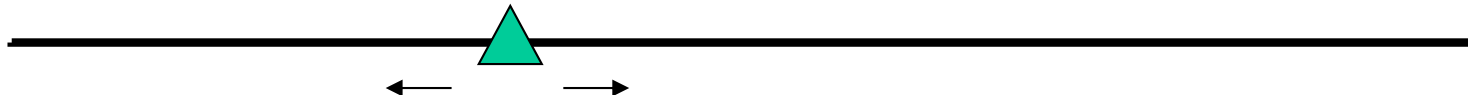

# Where to put QoS?

## OSI Model

Application

Presentation

Session

Transport

Network

Data Link

Physical

## TCP/IP Model

Application

Transport

Internet

Network  
Access

# MUST maintain IP philosophy

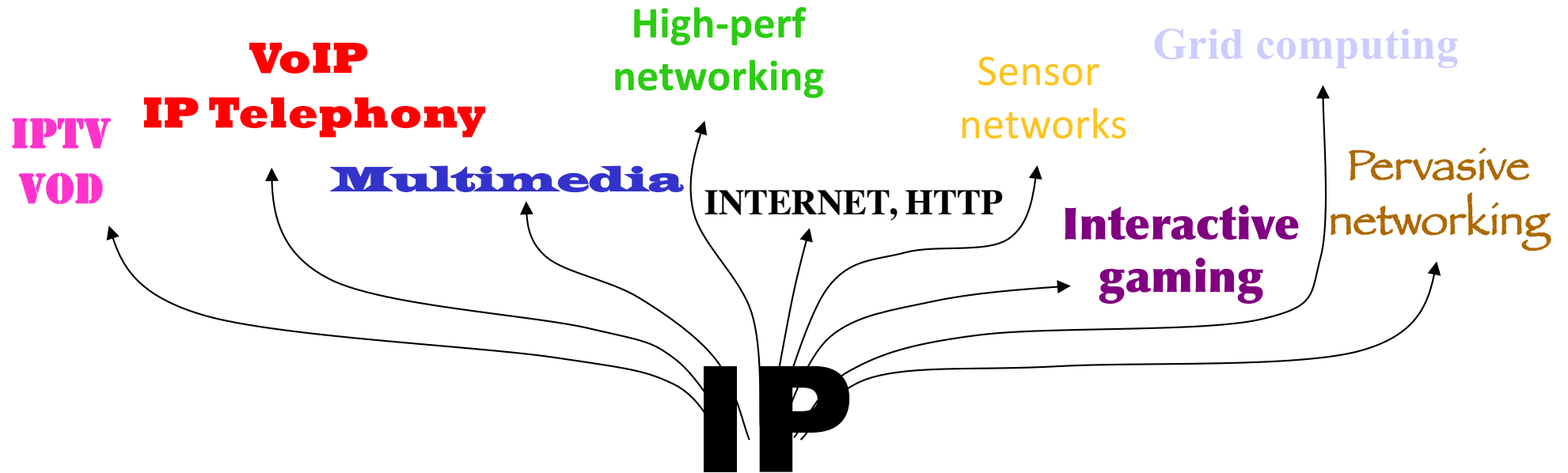

Application layer=network as a black box



# Dealing with packet jitter Fixed playout delay

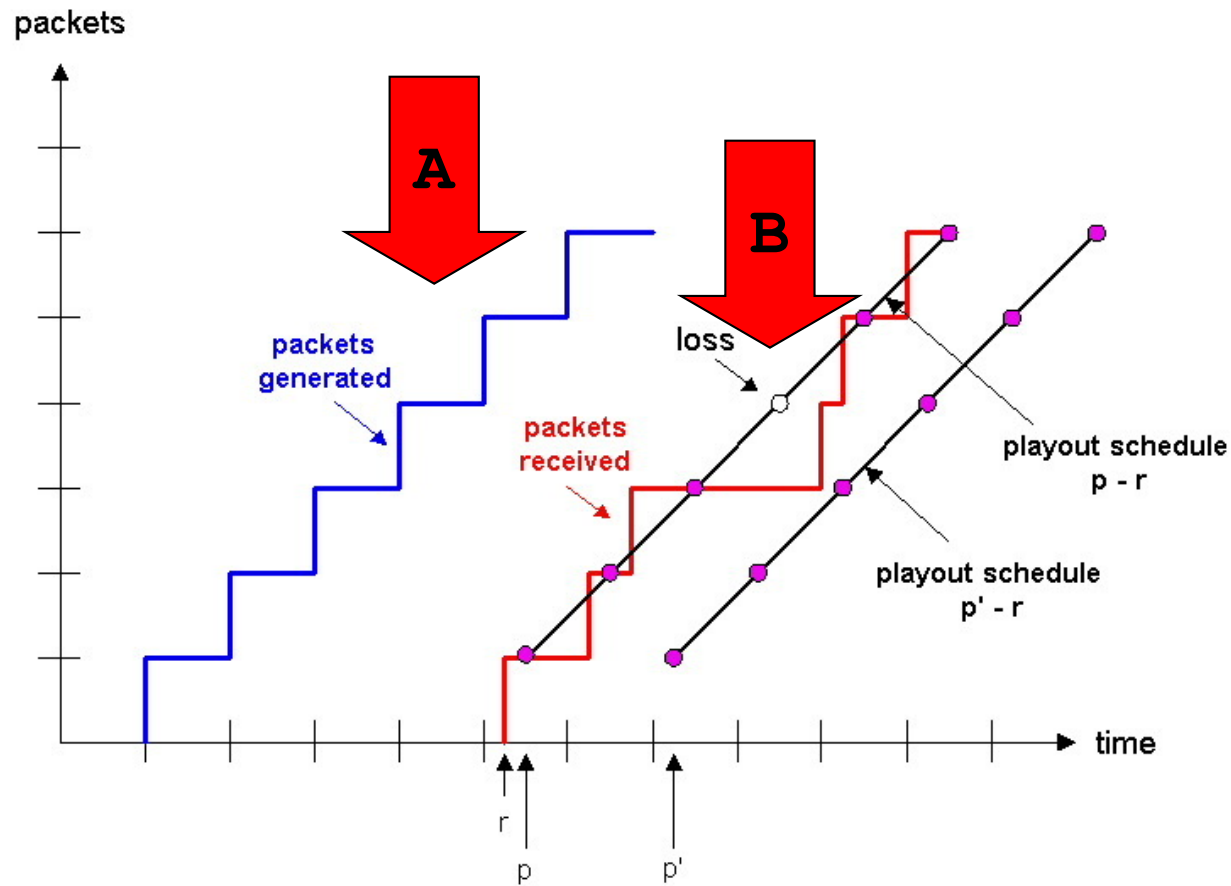

From Xavier Appé, modified by C. Pham for educational purpose only

# Recovering from packet loss Interleaving

- Divide 20 msec of audio data into smaller units of 5 msec each and interleave
- Upon loss, have a set of partially filled chunks

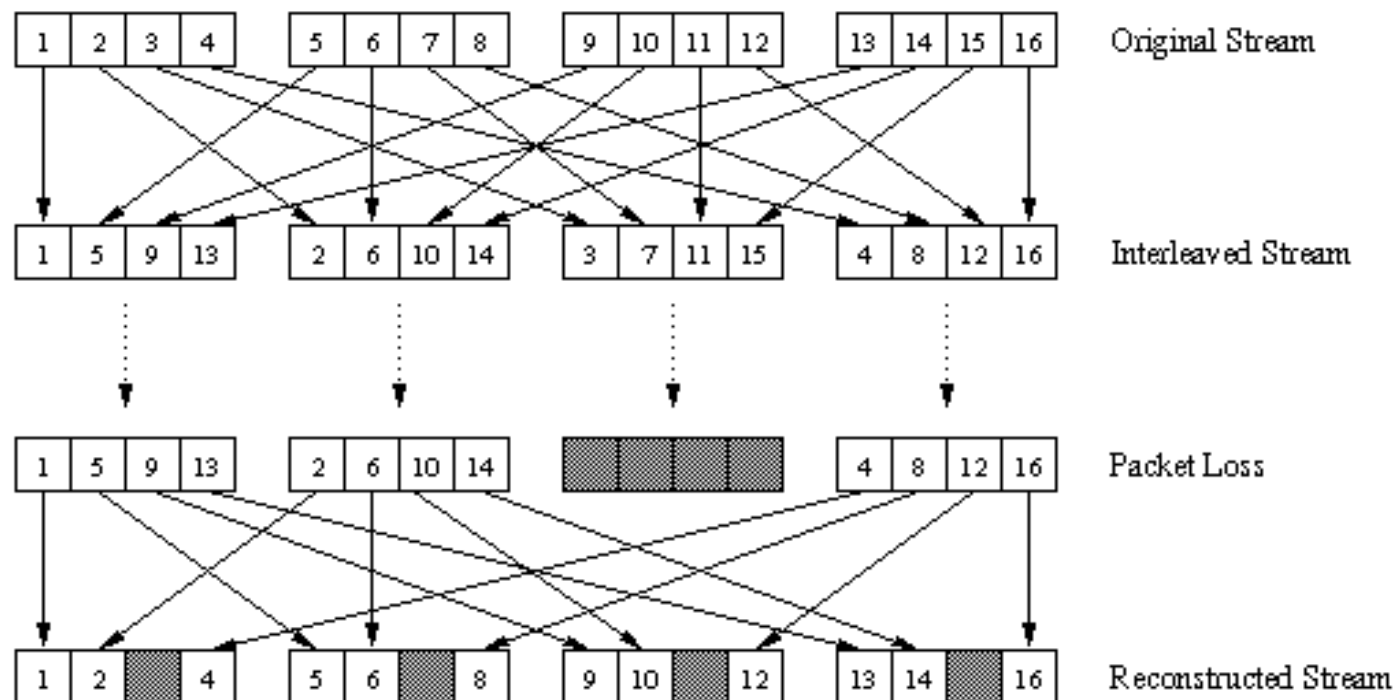

From Xavier Appé, modified by C. Pham for educational purpose only

# Large block FEC codes...

- an example: LDPC code
  - based on XOR operations ( $\oplus$ )
  - uses bipartite graphs between source and FEC symbols
  - iterative decoding

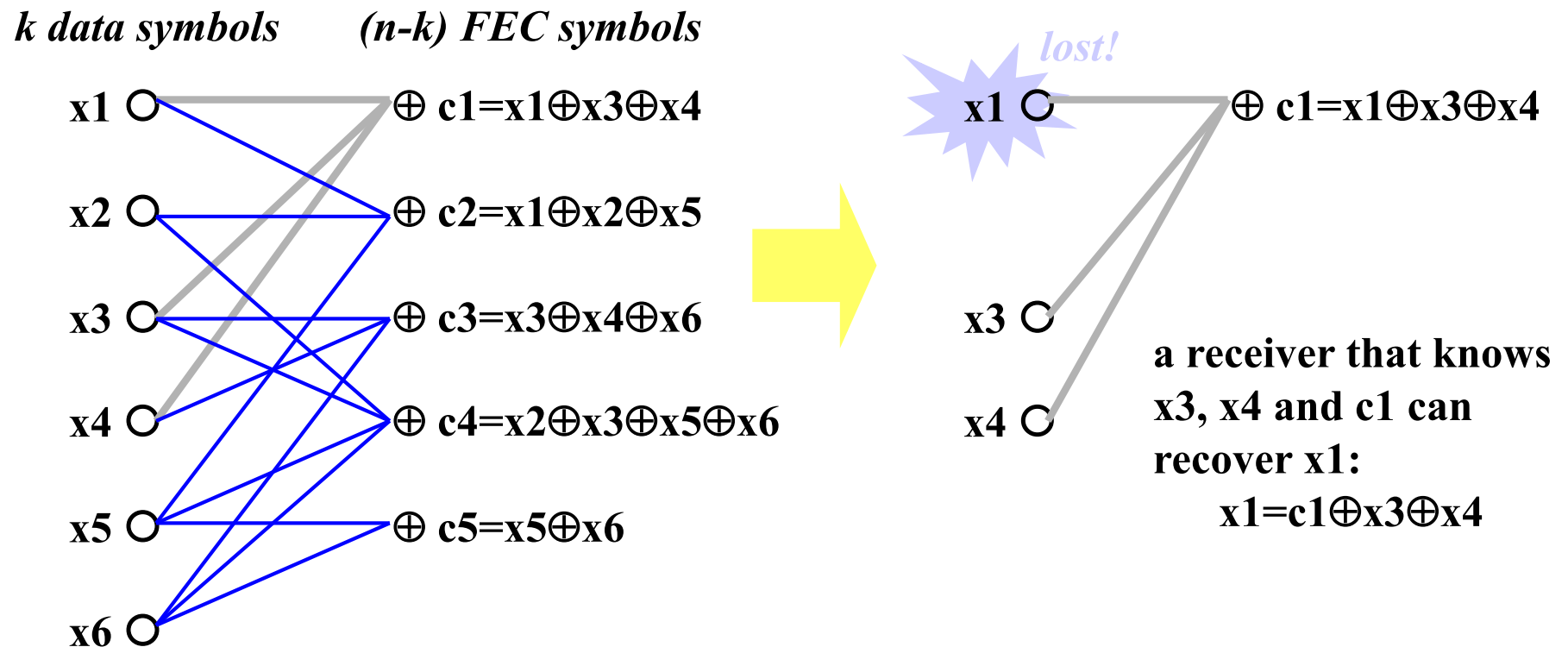

From Xavier Appé, modified by C. Pham for educational purpose only

# DASH: Dynamic Adaptive Streaming over HTTP

The DASH standard is a video streaming technique based on segments, available in various quality and transferred with HTTP 1.1

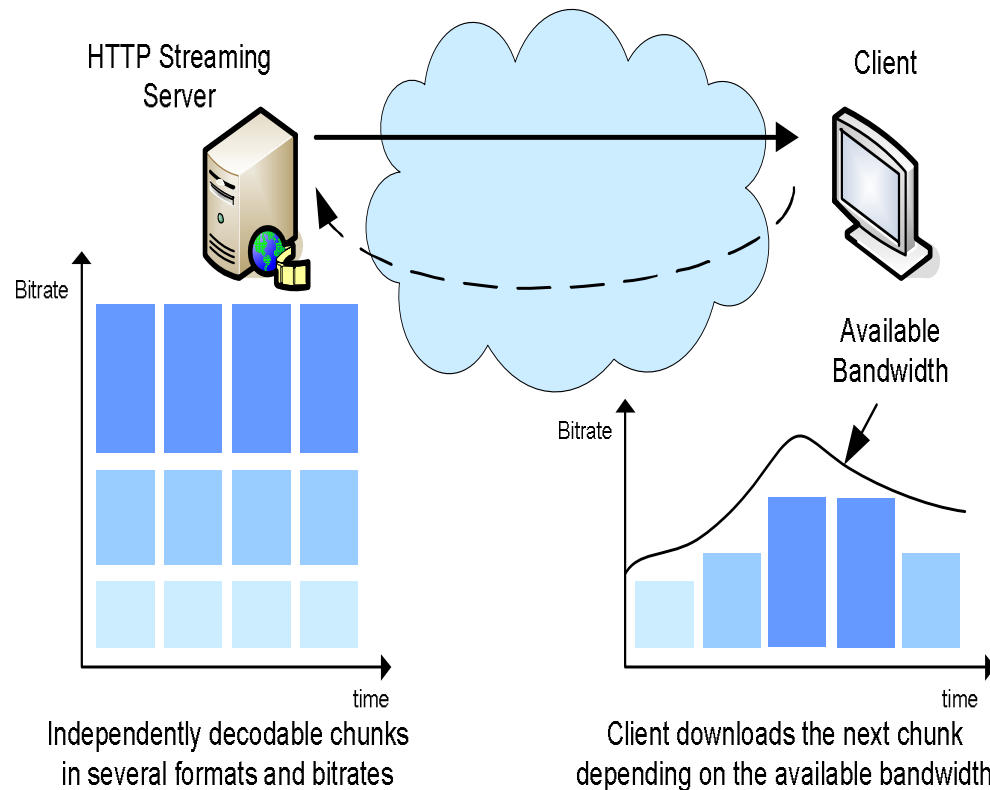



# Overprovisioning in the core

- ❑ Most operators are overprovisioning bandwidth with DWDM fibers
- ❑ 10Gbps, 40Gbps, 160 GBps, 320 Gbps
- ❑ Overprovisioning is a short-term solution that prevents optimizations

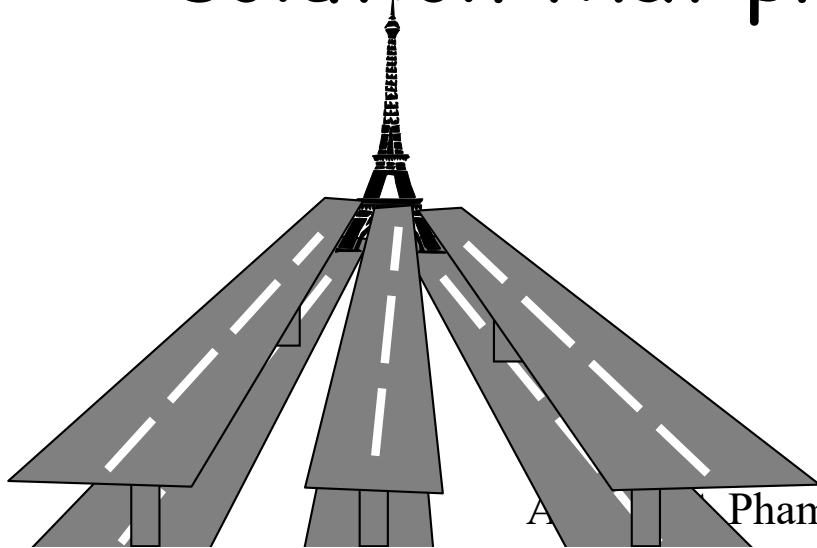

# IP desired service

- ❑ Isolation: my traffic is not impacted at all by yours
- ❑ Protection: my transmission path is backed up to the nth degree by failover paths
- ❑ Throughput: I get the capacity I pay for
- ❑ Delay: Whatever pattern of packets timing I send with is preserved at the far-end

# 30 years of INTERNET QoS...

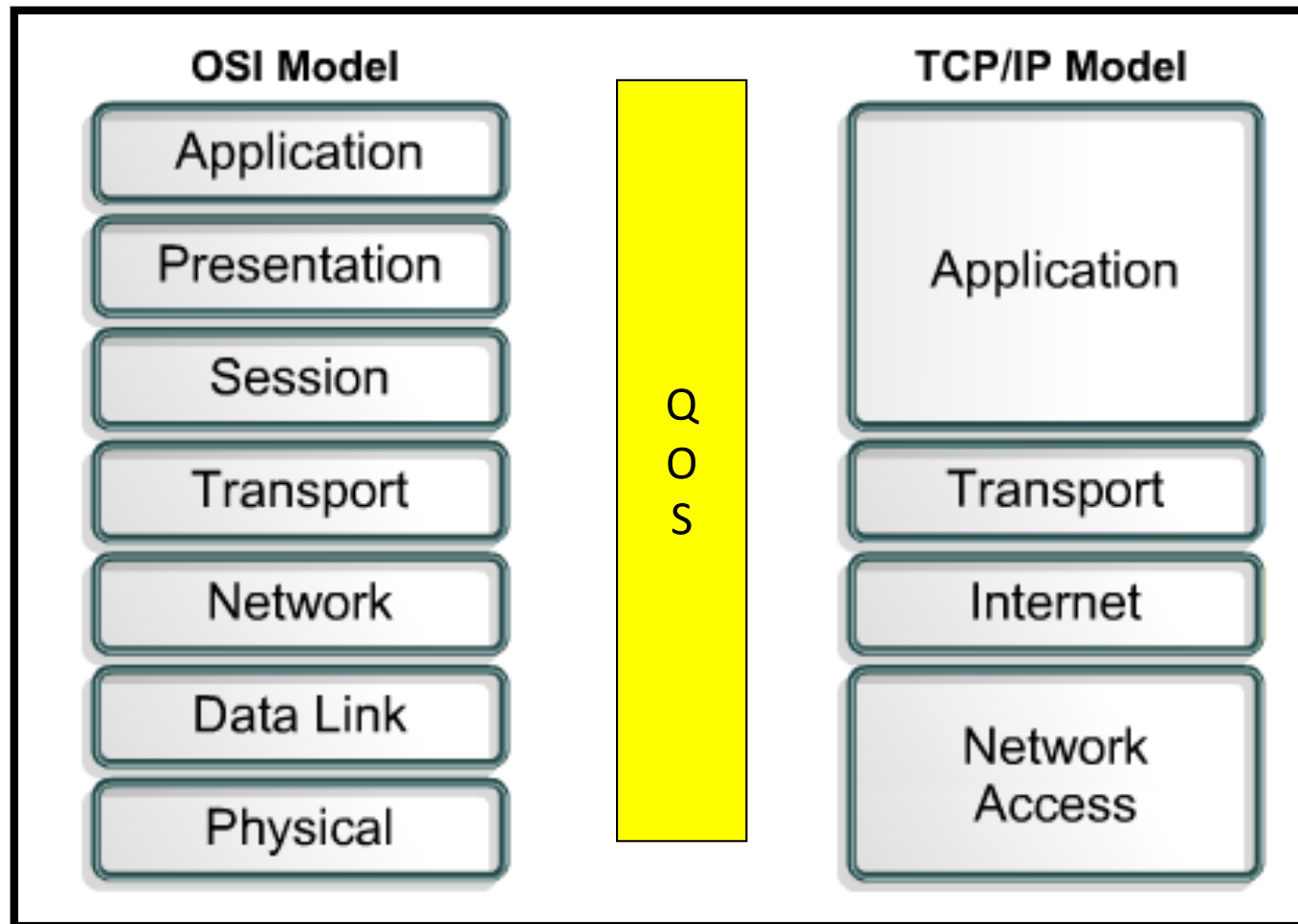

...have shown the power of selfishness!

Why should I  
bother with  
QoS when...

...others don't  
do it?



# It's not my fault!

« environmental problems often have impacts beyond borders »

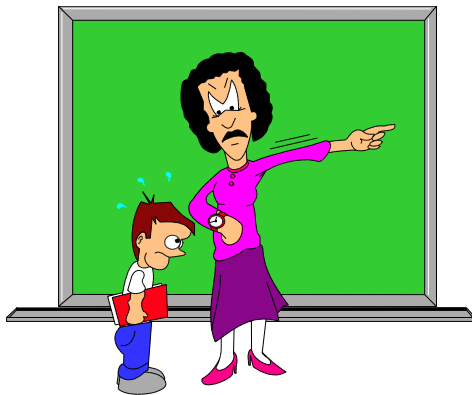

- ❑ What's the point of deploying QoS if others don't?

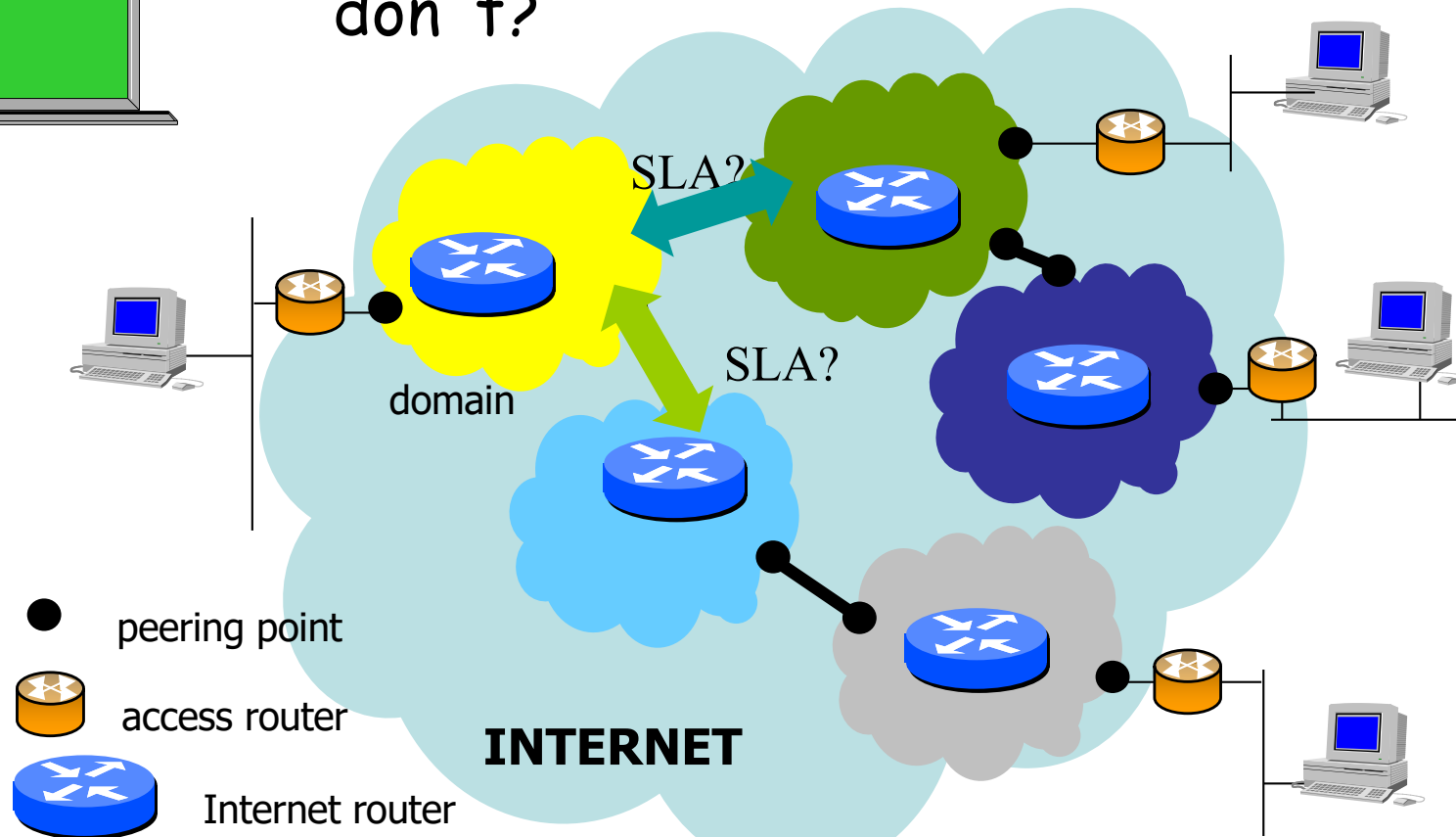

# Current Internet's QoS

QoS

IT WORKS!

So why change?

# Sustainable development

- ❑ "meets the needs of the present without compromising the ability of future generations to meet their own needs" [Brundtland Report, 1987]
- ❑ Trade-off between performance and needs: « why are we producing? »
- ❑ Use the right resource, at the right place, at the right time

a new dimension of global responsibility—  
not only to planetary resources but also to planetary  
fairness



# Is overprovisioning harmful?

- ❑ NO: overprovisioning is not very costly. Adding new wavelengths is quick. Customers are happy and quick return on investment!
- ❑ YES: while overprovisioning, alternative solutions are not deployed. High risk that relying too much on old technologies makes upgrades impossible (c.f. IPv6, TCP,...)



# Lessons learned from sustainable development

- Limit globalization
- Limit the pursuit of continued economic prosperity
- Redistribute labour, wages,...
- Promote the use of local resources
- Change mentality

# Community networks?



# Limitations of the current Internet

- ❑ Bandwidth
  - ❑ Raw bandwidth is not a problem: DWDM
  - ❑ Provisioning bandwidth on demand is more problematic
- ❑ Latency
  - ❑ Mean latencies on Internet is about 80-160ms
  - ❑ Bounding latencies or ensuring lower latencies is a problem
- ❑ Loss rate
  - ❑ Loss rate in backbone is very low
  - ❑ End-to-End loss rates, at the edge of access networks are much higher
- ❑ Communication models
  - ❑ Only unicast communications are well-defined: UDP, TCP
  - ❑ Multi-parties communication models are slow to be deployed

# Net Neutrality or Not?

- ❑ NN or NNN? That's the question!
- ❑ NN = dumb network!
- ❑ Internet's success is in a large part debtful to what's called Net Neutrality (IP neutrality)

# Some NN success stories

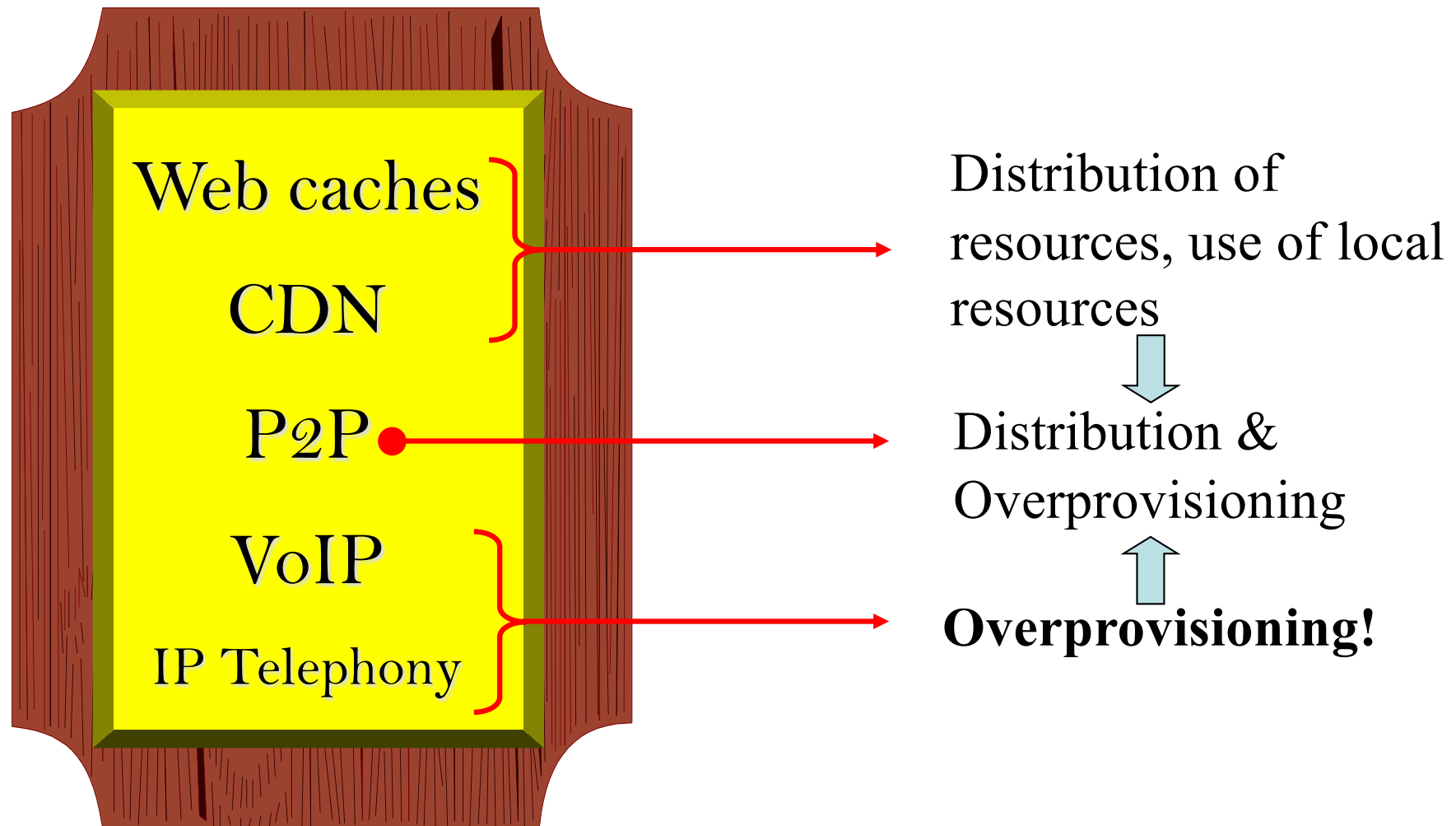

# CDN

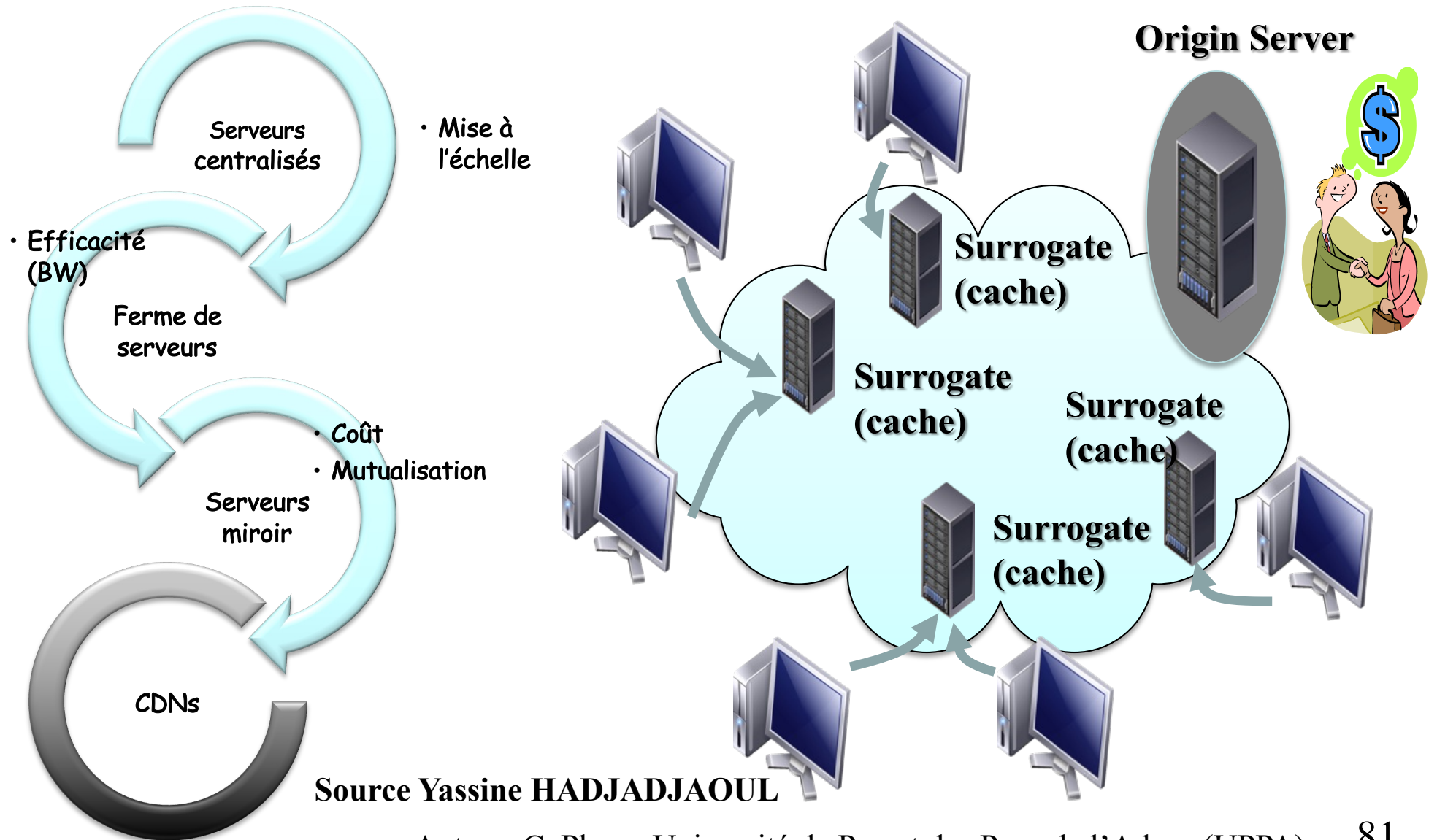

Source Yassine HADJADJAOL



## The Akamai EdgePlatform:

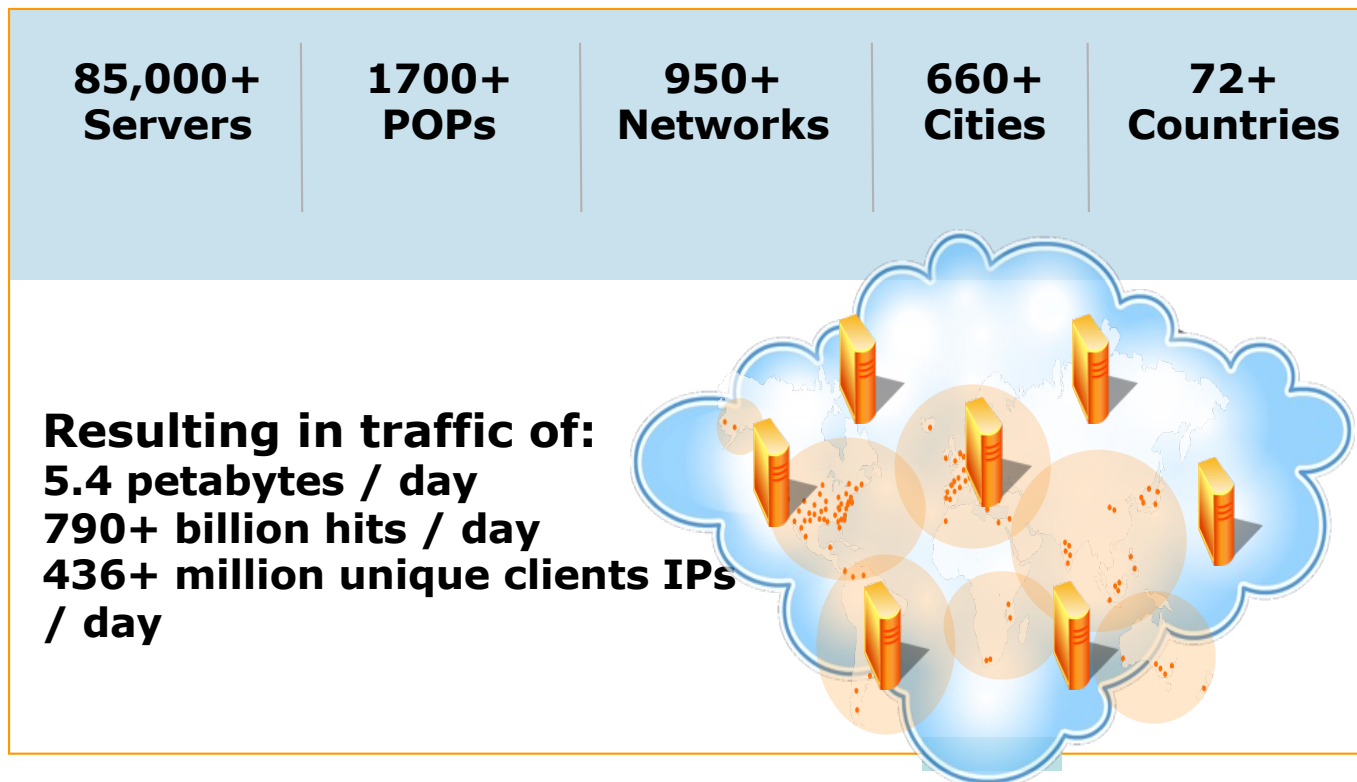

Source Yassine HADJADJAOL

# CDNs traffic evolution

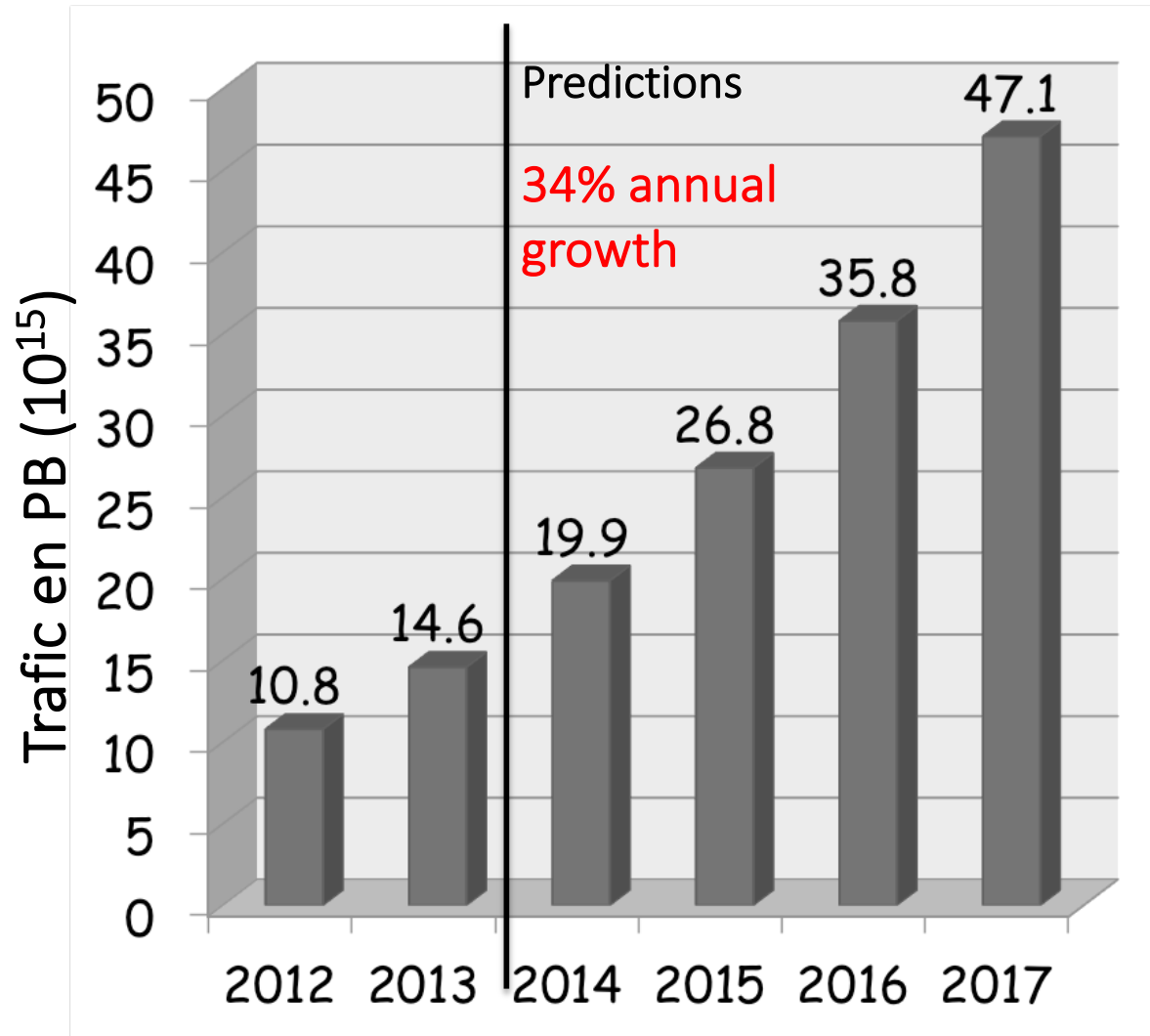

Source Yassine HADJADJAOL

- **Dominating** method for streaming.
  - 51% of Internet traffic will go through CDNs in 2017 (34% in 2012).
  - 65% of video traffic on Internet will go through CDNs in 2017 (53% in 2012)



# CDN market size

Global Content Delivery Network Market Size, By Application, 2020 & 2027 (USD Million)

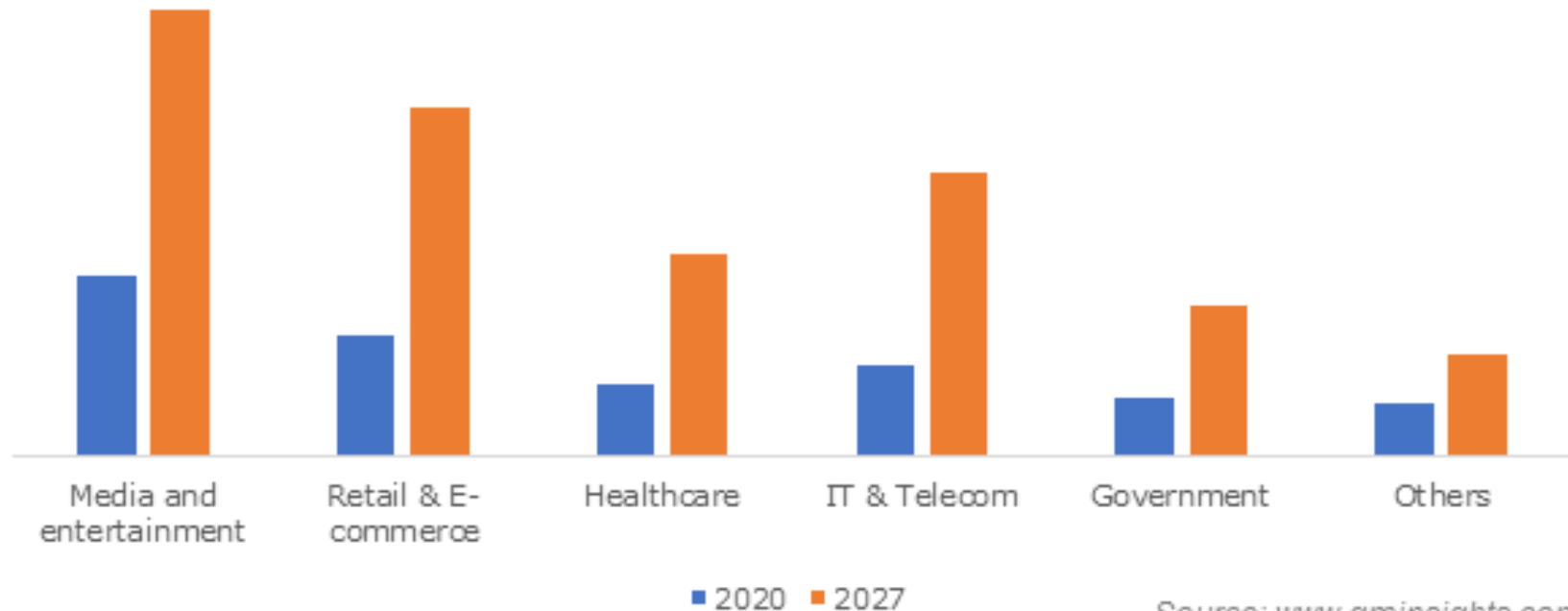

Source: [www.gminsights.com](http://www.gminsights.com)

# Typical architecture

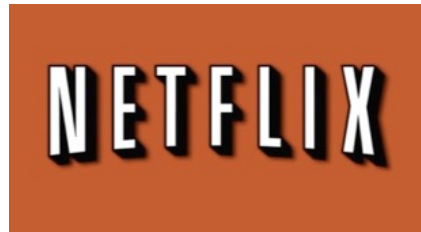

Source Yassine HADJADJAOL

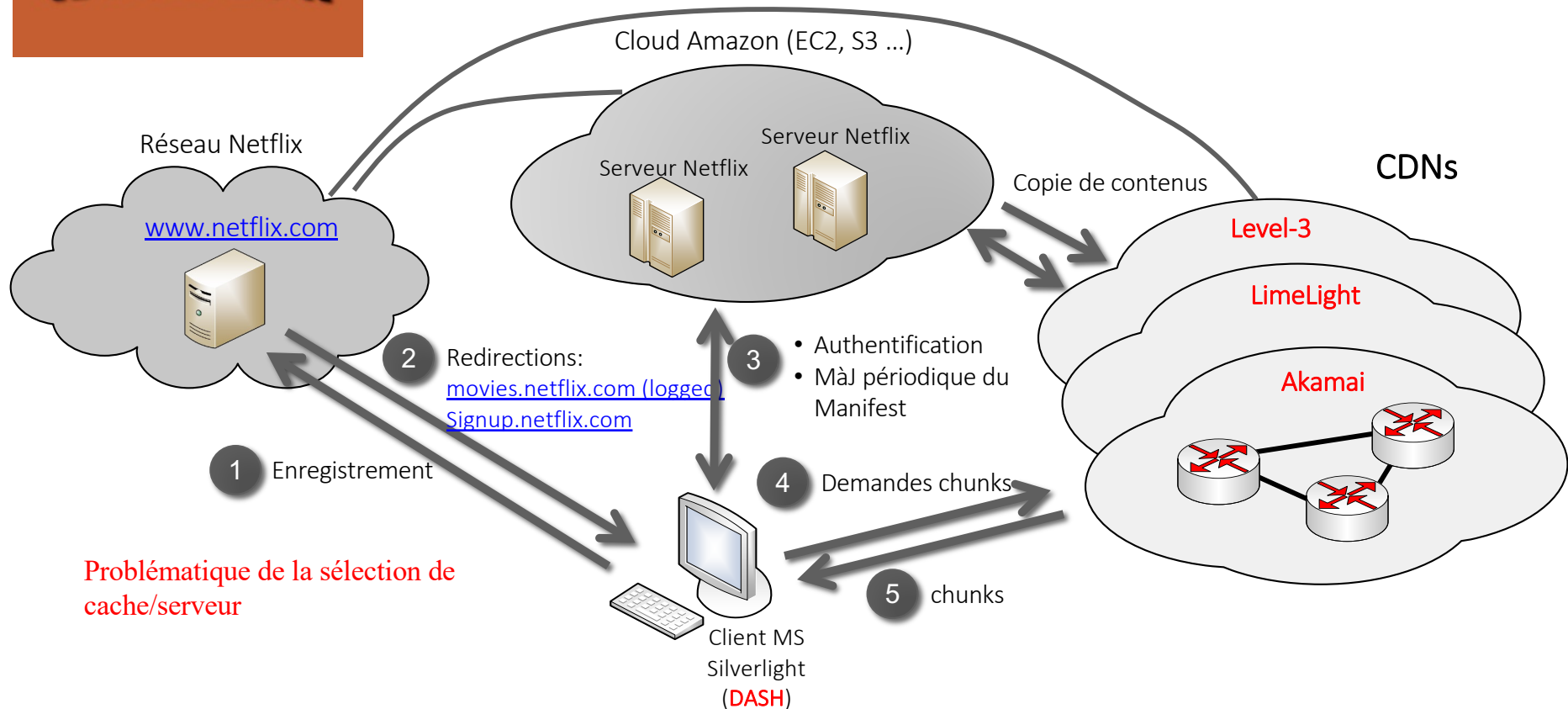

V. K. Adhikari, Y. Guo, F. Hao, M. Varvello, V. Hilt, M. Steiner, and Z.-L. Zhang. INFOCOM, page 1620-1628. IEEE, (2012)

# Where to put QoS?

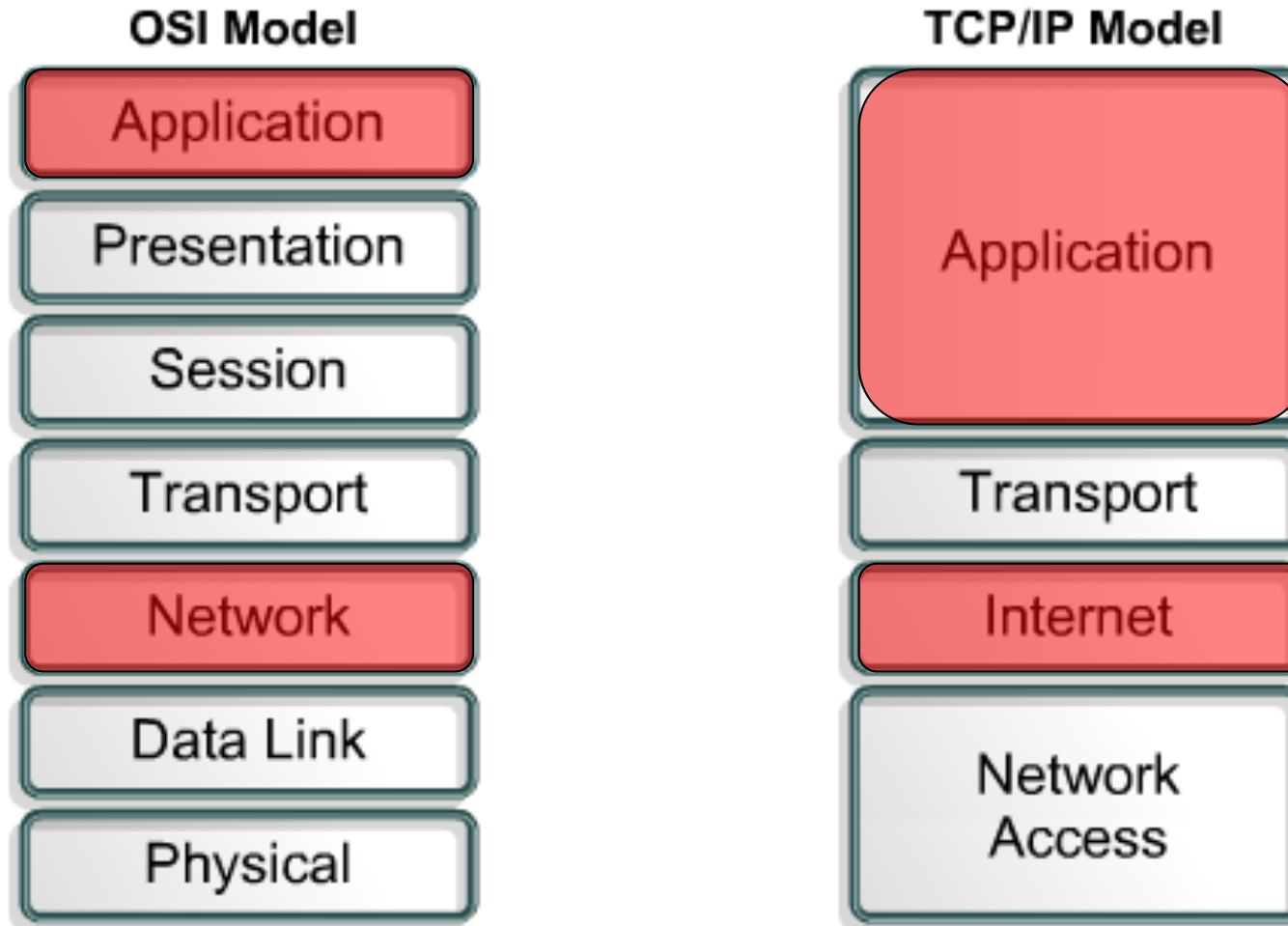

# Internet Routers



©cisco



©Juniper

PRO/8812



PRO/8801



©Procket Networks



©Alcatel

©Lucent



©Nortel Networks

and more...

# If no NN then give more power to routers!

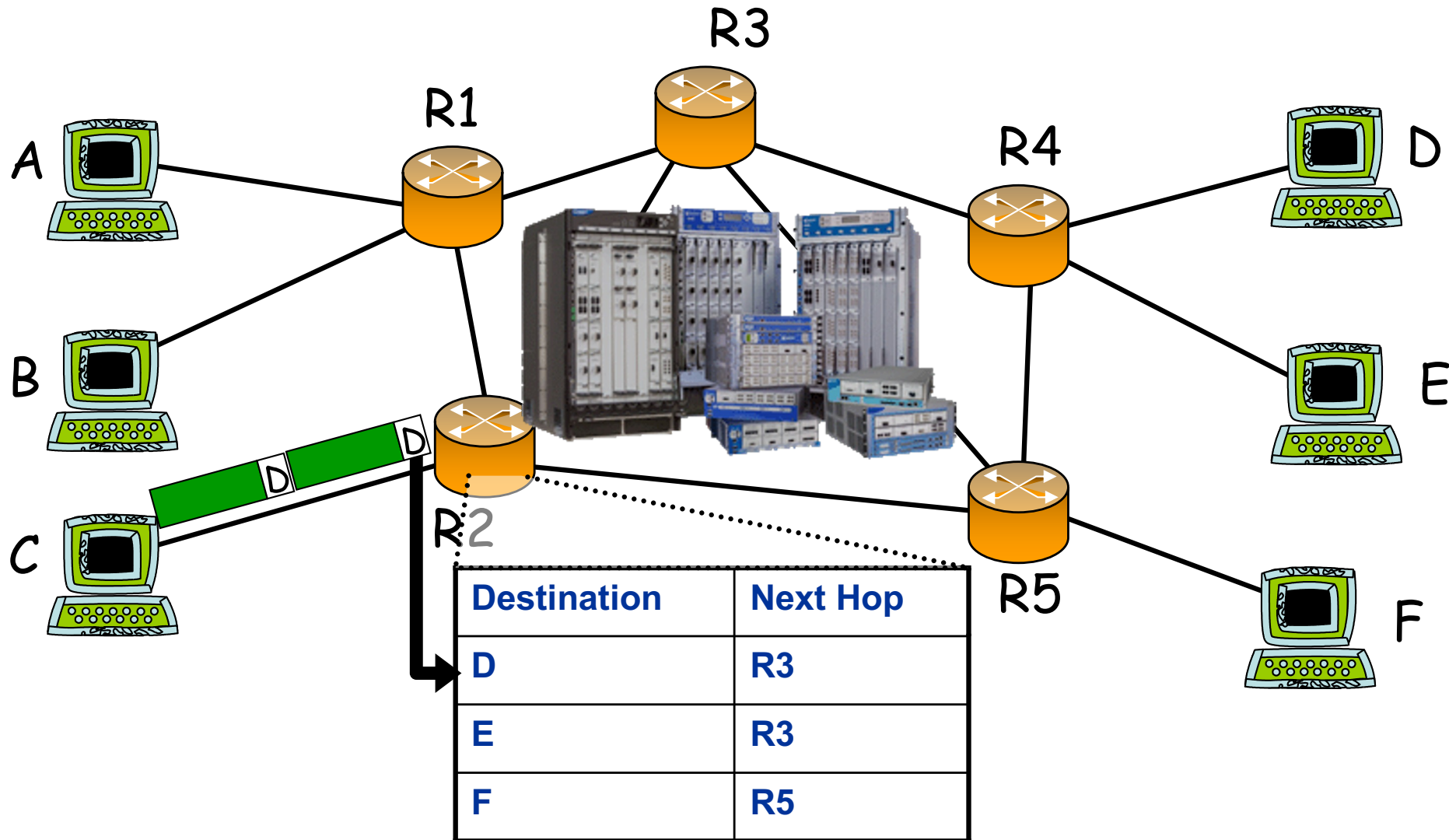

# General architecture of an IP router

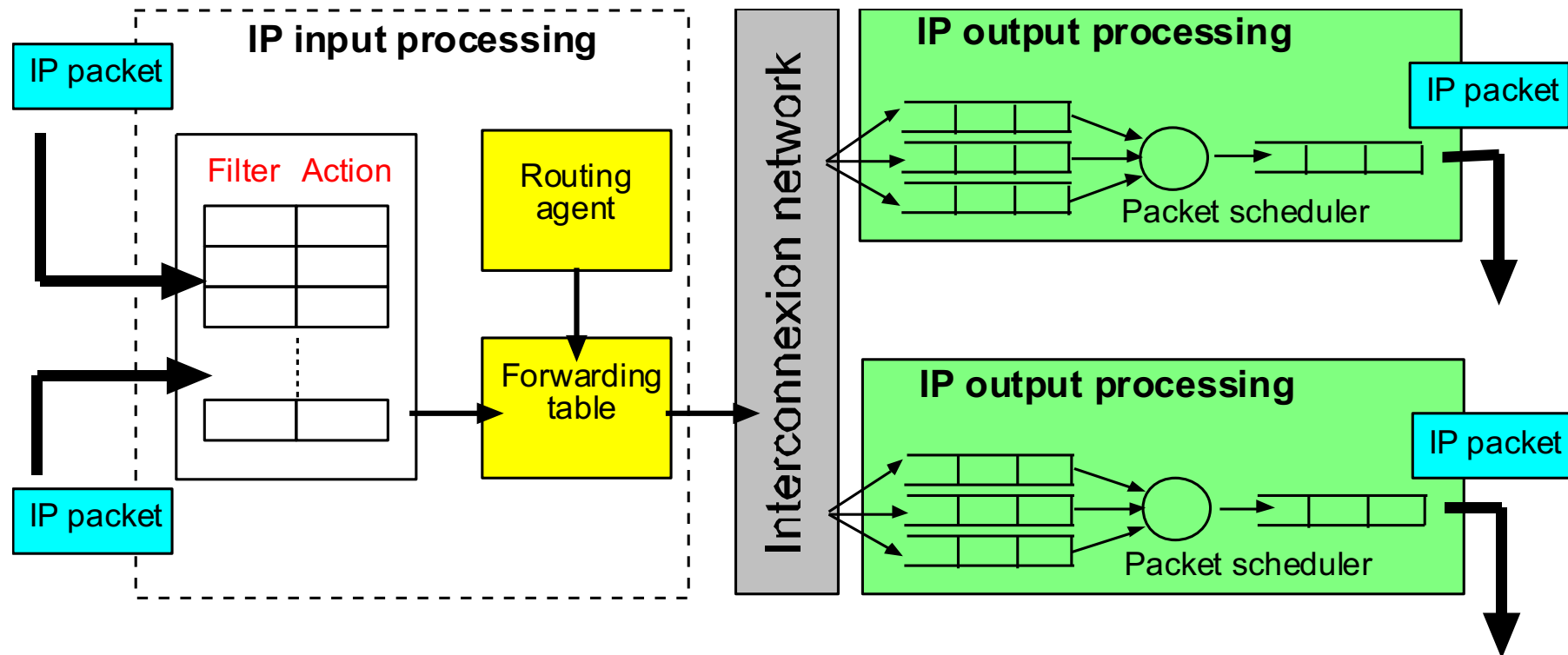

- ❑ receives input packets,
- ❑ sends packets to output buffers,
- ❑ transmits packets.

# In 2000, I had a dream: active networking!

- ❑ Programmable nodes/routers
- ❑ Customized computations on packets
- ❑ Standardized execution environment and programming interface
- ❑ No killer applications, only a different way to offer high-value services, in an elegant manner
- ❑ However, adds extra processing cost

# Motivations behind Active Networking

- ❑ From the user perspective
  - ❑ applications can specify, implement, and deploy (on-the-fly) customized services and protocols
- ❑ From the operator perspective
  - ❑ reduce the latency/cost for new services deployment/management
- ❑ From the network perspective
  - ❑ globally better performances by reducing the amount of traffic



# Active networks implementations

- ❑ Discrete approach (operator's approach)
  - ❑ Adds dynamic deployment features in nodes/routers
  - ❑ New services can be downloaded into router's kernel
- ❑ Integrated approach
  - ❑ Adds executable code to data packets
  - ❑ Capsule = data + code
  - ❑ Granularity set to the packets

# The discrete approach

- Separates the injection of programs from the processing of packets

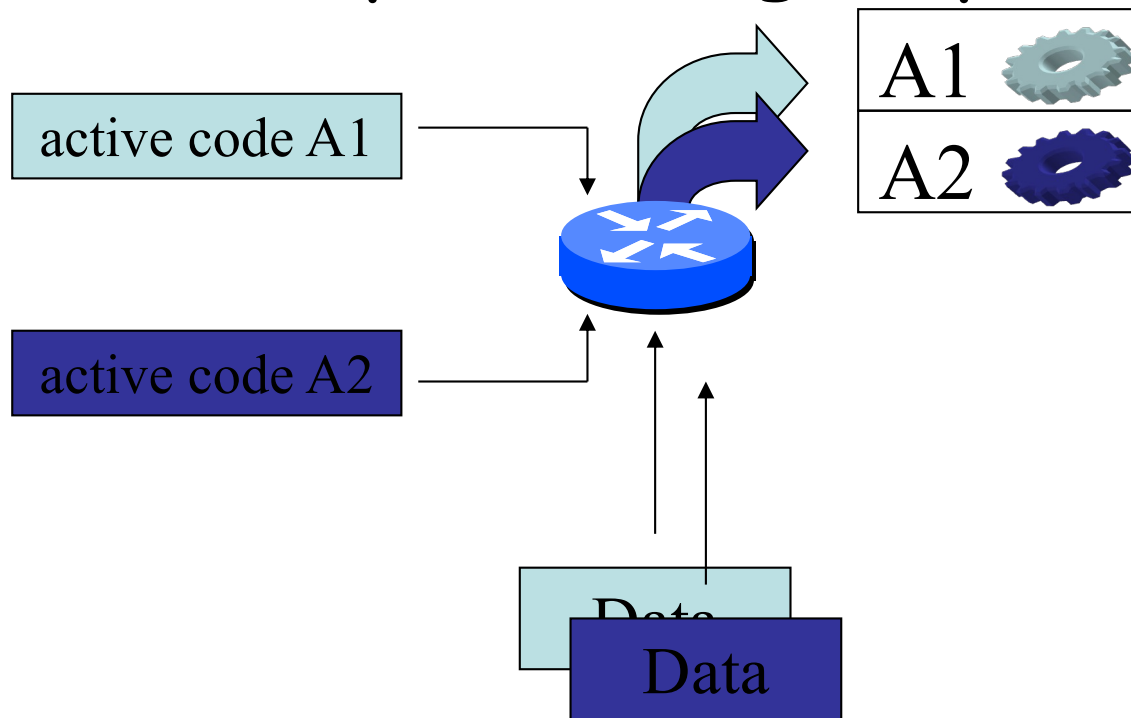

# The integrated approach

- User packets carry code to be applied on the data part of the packet

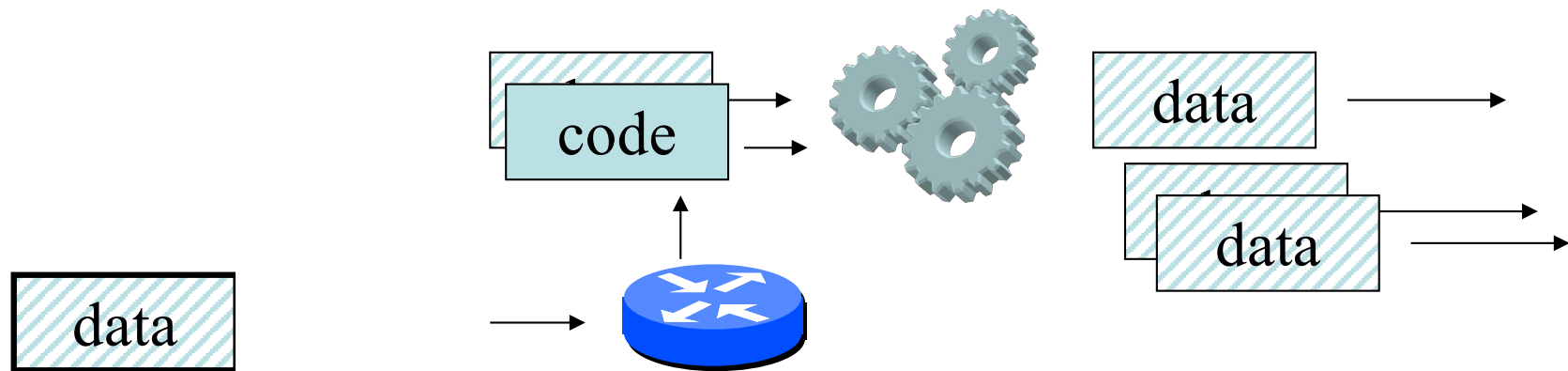

- High flexibility to define new services

# An active router

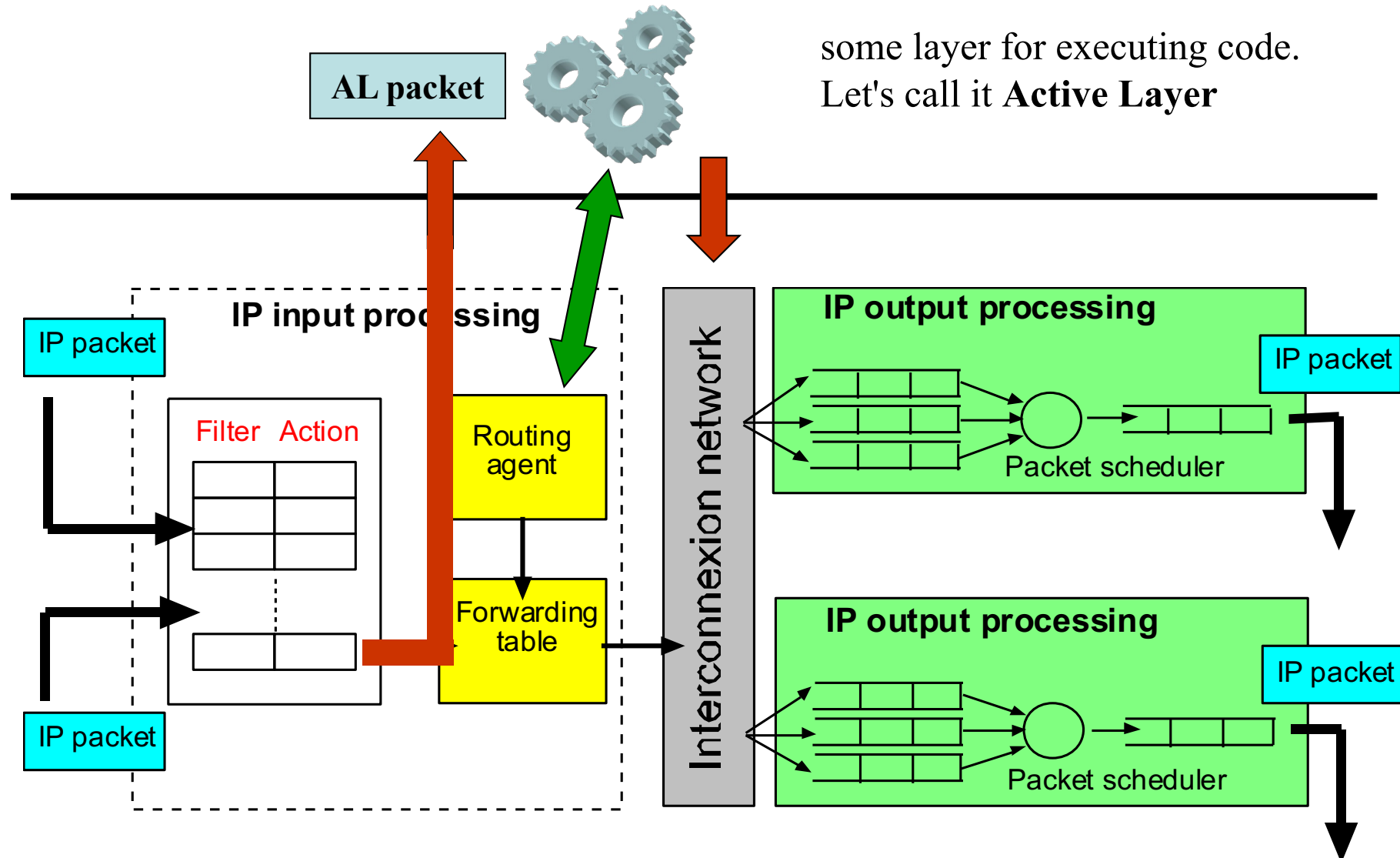

some layer for executing code.  
Let's call it **Active Layer**

# Interoperability with legacy routers

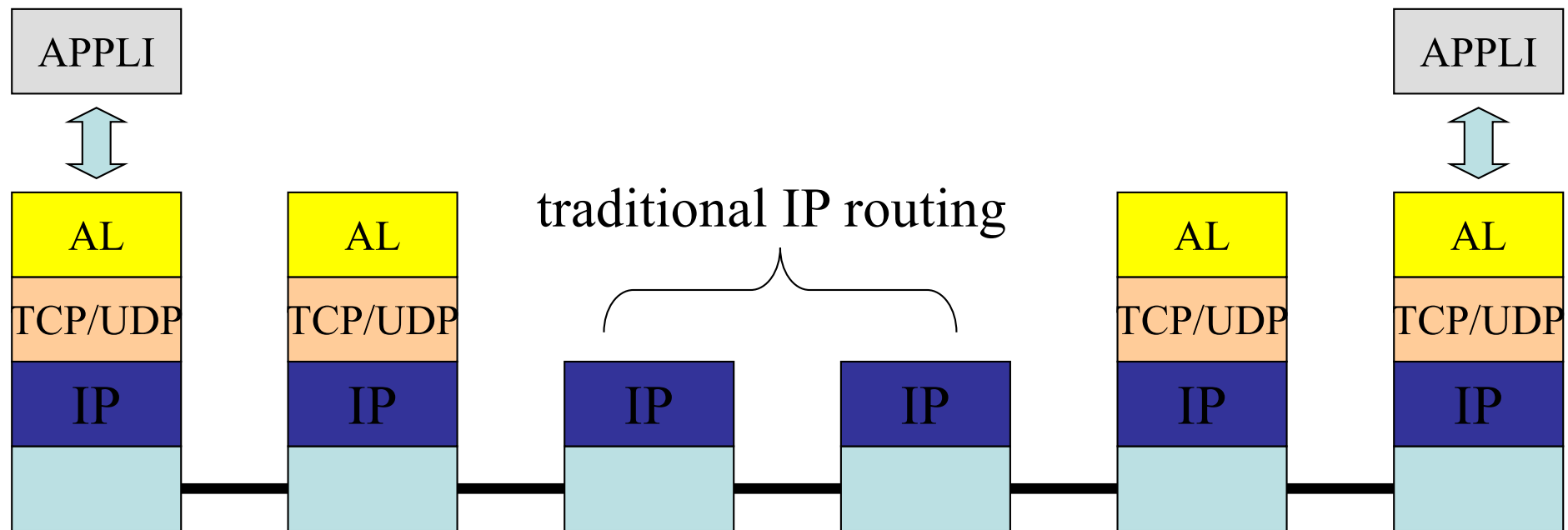

# Active network revisited

- ❑ Software Defined Networking (SDN) wants to decouple the control plane from the data plane.
- ❑ Network Function Virtualization (NFV) complements SDN by using commodity servers to run network services software versions that previously were hardware-based.
- ❑ Somehow similar to discrete active/programmable network concepts
- ❑ Better perception from the user because controlled by operators and hardware vendors
- ❑ Made possible with advances in virtualization techniques

# How to upgrade the Internet for QoS?

- ❑ **Approach:** de-couple end-system evolution from network evolution
- ❑ **End-to-end protocols:** TCP, RTP, H.323, etc to spur the growth of adaptive multimedia applications
  - ❑ Assume best-effort or better-than-best-effort clouds
- ❑ **Network protocols:** IntServ, DiffServ, RSVP, MPLS, COPS ...
  - ❑ To support better-than-best-effort capabilities at the network (IP) level